

# 저압 계기용 변성기

## Low Voltage Current Transformer

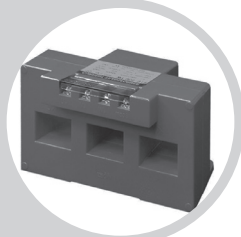
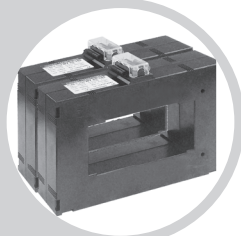
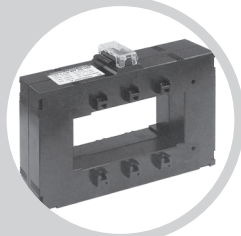
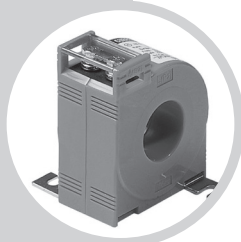

모델구분표(Model Description).....	854
관통형 변류기(Round type CT).....	855
권선형 변류기(Winding type CT).....	859
부스바용 변류기(Busbar type CT).....	861
3Ø 일체형 변류기(3Ø Current CT).....	870
분할 변류기(Split type CT).....	873
변압기(Voltage Transformer VT).....	875
3Ø 일체형 변압기(3Ø Voltage Transformer VT).....	878

# 주문시 확인 승낙 사항

## Items to be verified and approved when ordering products

### 운영 제품을 구입하는 고객 여러분께!

저희 운영 제품을 애용해 주셔서 대단히 감사합니다.  
본 카탈로그에서 당사 제품을 주문하실 경우, 견적서, 계약서, 사양서 등에 특기사항이 없는 경우에는 다음의 적합 용도조건, 보증내용등을 적용합니다.  
아래 내용을 확인하시고 승낙하신 후 주문해 주십시오.

#### 1. 보증 내용

- ① 보증기간  
당사 제품의 보증기간은 구입 후 또는 지정 장소 납입 후 1년으로 합니다.
- ② 보증 범위  
상기 보증 기간 중에 당사측의 책임으로 당사 제품에 고장이 발생한 경우 대체품 제공 또는 수리를 제품 구입 장소에서 무상으로 실시합니다. 단, 고장의 원인이 다음에 해당하는 경우에는 이 보증 대상 범위에서 제외됩니다.
  - a) 본 카탈로그 또는 사양서에 기재되어 있는 이외의 조건, 환경, 취급 및 사용에 의한 경우
  - b) 당사 제품 이외의 원인에 의한 경우
  - c) 당사 이외에 의한 개조 또는 수리에 의한 경우
  - d) 당사 제품의 본래 사용법 이외의 사용에 의한 경우
  - e) 당사 출하 당시의 과하, 기술 수준으로는 예측 할 수 없었던 경우
  - f) 기타 천재지변, 재해 등 당사측의 책임이 아닌 원인에 의한 경우참고로 여기서의 보증은 당사 제품 단품의 보증을 의미하는 것이며, 당사 제품 고장에 의해 유발되는 손해는 보증 대상에서 제외됩니다.

#### 2. 책임의 제한

- ① 당사 제품에 기인해 발생한 특별손해, 간접손해, 또는 소극적 손해에 대해 당사는 일체의 책임을 지지 않습니다.
- ② 프로그래밍 가능한 당사제품에 대해 당사 이외의 자가 실시한 프로그램 또는 그에 의해 발생한 결과에 대해 당사는 일체의 책임을 지지 않습니다.

#### 3. 적합 용도의 조건

- ① 당사 제품을 다른 제품과 조합해서 사용하는 경우에 적합해야 할 규격, 법규 및 규제는 고객이 직접 확인해 주십시오.  
또 고객이 사용하시는 시스템, 기계, 장치에 대한 당사제품의 적합성은 고객이 직접 확인해 주십시오.  
이것이 실시되지 않는 경우 당사는 당사 제품의 적합성에 대해 책임을 지지 않습니다.
- ② 다음 용도에 사용하는 경우, 당사 영업 담당자와 상담하고 사양서 등을 통해 확인하는 한편 정격, 성능에 대해 여유를 주거나 만일 고장이 발생해도 위험을 최소화 할 수 있는 안전 회로 등의 안전 대책을 2중으로 강구해 주십시오.
  - a) 실외, 잠재적인 화학적 오염 또는 전기적 방해를 받는 용도 또는 본 카탈로그에 기재되지 않는 조건이나 환경에서 사용.
  - b) 원자력 제어설비, 소각설비, 철도, 항공, 차량설비, 의료용 기계, 반도체 제조장비, 오락기계, 안전장치 및 행정 기관이나 개별 업계의 규제에 따른 설비
  - c) 인명이나 재산에 위험이 미칠 수 있는 시스템, 기계, 장치
  - d) 가스, 수도, 전기의 공급 시스템, 24시간 연속 운전 시스템 등 높은 신뢰성이 필요한 설비
  - e) 자동차(2륜차 포함) 탑재 설비
  - f) 기타상기 a)~e)에 준하며 고도의 안전성이 필요한 용도
- ③ 고객이 당사 제품을 인명이나 재산에 중대한 위험을 미치는 용도에 사용하는 경우에는 시스템 전체적으로 위험을 알리거나 여유 있는 설계에 의해 필요한 안전성을 확보할 수 있도록 설계되어 있는지 당사 제품이 전체적으로 의도한 용도에 적절히 배전, 설치 되어 있는지 반드시 고객이 직접 사전에 확인해 주십시오.
- ④ 본 카탈로그에 기재되어 있는 용도는 참고용이므로 채택 시에는 기기, 장치의 기능과 안전성을 확인 한 후에 사용해 주십시오.
- ⑤ 당사 제품의 잘못된 사용으로 고객 또는 제 3자에게 예기치 않는 손해가 발생하지 않도록 사용상의 금지 사항 및 주의 사항을 완전히 숙지 한 후 반드시 지켜 주십시오.

#### 4. 사양변경

본 카탈로그에 기재된 제품의 사양 및 동봉품은 개선 또는 기타 사유에 의해 필요에 따라 변경될 수 있습니다.  
당사 영업 담당자와 상담하고 당사 제품의 실제 사양을 확인해 주십시오.

#### 5. 서비스의 범위

당사 제품의 가격에는 기술자 파견 등의 서비스 비용은 포함되어 있지 않습니다.  
원하실 경우에는 당사 영업 담당자와 상담해 주십시오.

#### 6. 적용 범위

상기 사항은 대한민국 내에서의 거래 및 사용을 전제로 합니다.  
해외에서의 거래 및 사용에 대해서는 당사 영업 담당자와 사전에 상담해 주십시오.

### Dear customers who purchase Woon Young products!

Thank you for purchasing Woon Young products.  
If there is no particular information on estimates, contracts or specifications when you order products from this catalog, the following conditions of use and warranty shall apply. Please place orders after you read and approve the following items.

#### 1. Content of Warranty

- ① Warranty period  
The warranty period of this product shall be 1 year from the date of purchase or from the day the product is delivered to a designated place.
- ② Scope of warranty  
If failure occurs due to reasons attributable to this company during the above-said warranty period, this company will provide substitute products or repair the product free of charge at the place of purchase. However, if the cause of failure is one of the following, it shall be excluded from being eligible for warranty benefits.
  - a) Products were handled or used under the conditions and environment not entered in this catalog or in specification.
  - b) Failure occurred due to reasons other than those caused by this product.
  - c) Failure occurred due to modification or repairs performed by persons other than this company.
  - d) Failure occurred because the product was used based on the method other than the original usage of this product.
  - e) Failure was not expected by the scientific and technical levels prevailing at the time of shipment.
  - f) Failure occurred due to causes beyond the control of this company, e.g. natural disasters and accidents.Warranty as specified herein means the warranty covering only the product of this company, and any damage caused by the failure of this product shall be excluded from being eligible for warranty coverage.

#### 2. Limitations on responsibility

- ① This company shall not be held liable whatsoever for any special damage, indirect damage or passive damage caused by this product of this company.
- ② This company shall not be held liable whatsoever for any programming performed by persons other than this company on the programmable products or for the results of such programming.

#### 3. Conditions of compatibility

- ① Please check the standards, laws and regulations applicable when this product is used in combination with other products.  
In addition, be sure to check the compatibility of this product covering the systems, machines and devices used by you.  
If you fail to take actions as above, this company shall not be held liable for the compatibility of the product.
- ② If the product is used for the following purposes, discuss details with the sales manager of this company based on the provided specifications. At the same time, allow sufficient rating and performance, or take appropriate safety measures through the safety circuits that can minimize risks even if failure occurs.
  - a) Using the product outside or under environment exposed to potential chemical pollution or electric interference, or using the products under the conditions or environment not specified in this catalog.
  - b) Nuclear controllers, incinerators, railways, aviation, vehicles, medical equipment, semiconductor manufacturing equipment, game machines, safety devices and equipment regulated by administrative agencies or individual maker.
  - c) Systems, machines and devices that can cause personal or property damage.
  - d) Equipment requiring high degree of reliability, e.g. gas, water and electricity supply systems, and 24-hour continuous operation systems.
  - e) Automobile (Including two-wheeled vehicles) mounted equipment
  - f) Other purposes equivalent to the above-said paragraph a) through e) requiring high degree of safety.
- ③ If the product is used for purposes that might induce serious personal or property damage, be sure that you inform risks covering the entire system in advance or verify whether the product is designed to ensure required safety or whether the product is properly connected and installed to suit the intended overall purposes
- ④ The purposes of the products shown in this catalog are only for reference purposes. Apply such purposes only after you check the functions and the safety of the equipment and devices.
- ⑤ To prevent unexpected damage to you or to third parties resulting from improper use of this product, be sure to use the product after you thoroughly read and understand items related to prohibitions and caution during use.

#### 4. Changing specifications

The products and specifications entered in this catalog are subject to change as needed for improvement or for other reasons. Discuss with the sales manager of this company and verify actual specifications of the products.

#### 5. Range of service

The product prices do not contain any service expenses, e.g. dispatch of technicians. If you need any services, discuss with the sales manager of this company.

#### 6. Scope of application

Items described above are on the premise that the products are traded and used in the Republic of Korea. Discuss with the sales manager of this company regarding overseas transactions and uses.

# GUIDELINES FOR SAFETY

## 안전을 위한 주의사항 Guidelines for Safety

- “안전을위한 주의사항” 은 제품을 안전하고 올바르게 사용하여 사고나 위험을 미리 막기 위한 것이므로 반드시 지켜 주십시오.
- 주의사항은 “경고”와 “주의”의 두 가지로 구분되어있으며 “경고” 와 “주의”의 의미는 다음과 같습니다.

- Guidelines for safety is to use product safe and properly and prevent accidents or dangers. Never forget to keep it.
- Guidelines can be classified into two, warning and caution, and their meanings are as follows.

**⚠ 경고** 지시사항을 위반하였을 때 심각한 상해나 사망이 발생 할 가능성이 있는 경우입니다.

**⚠ 주의** 지시사항을 위반하였을 때 경미한 상해나 제품손상이 발생할 가능성이 있는 경우 입니다.

- 제품과 사용설명서에 표시된 ⚠ 그림기호의 의미는 특정 조건 하에서 위험이 발생 할 우려가 있으므로 주의하라는 기호입니다.

**⚠ Warning** When there is the possibility that serious injury or death can occur when violating directions.

**⚠ Caution** When there is the possibility that slight injury or the damage of products can occur when violating directions.

- The meaning of ⚠ lexigram indicated on the products and instructions is to handle with care as any danger can occur under specific conditions.

### ⚠ 경고

1. 인명이나 재산상에 영향이 큰 기기 (예: 원자력제어, 의료기기, 차량, 철도, 항공, 연소장치, 오락기기 등 또는 안전장치)에 사용할 경우 반드시 2중으로 안전장치를 부착한 후 사용하여 주십시오.
  - 화재, 인명사고, 재산상의 손실이 발생할 수 있습니다.
2. 반드시 패널에 취부 하여 사용하고 FG 또는  $\perp$  단자는 접지하여 주십시오.
  - 감전의 우려가 있습니다.
3. 전원이 인가된 상태에서 결선 및 점검, 보수를 하지 마십시오.
  - 감전의 우려가 있습니다.
4. 자사 수리기술자 이외에는 제품을 개조하지 마십시오.
  - 감전이나 화재의 우려가 있습니다.
5. 입력 전원사양을 반드시 확인하시고 전원 연결 시 반드시 단자번호를 확인하시고 연결하십시오.
  - 화재의 우려가 있습니다.
6. 전원을 차단한 직후에 부하측 단자를 만지지 마십시오.
  - 감전의 우려가 있습니다.

### ⚠ Warning

1. When using in instruments that have great influence on lives or properties(for examples: nuclear energy control, medical equipment, vehicles, railroad, aviation, combustion apparatus, entertainment systems or safety device), use after being sure to attach duplex safety device.
  - There may be fire, loss of lives, or property damages.
2. Use after being sure to attach to panel, and ground FG or  $\perp$  terminal.
  - There may be the possibility of electric shock.
3. Don't connect, inspect and repair under the power-up.
  - There may be the possibility of electric shock.
4. Don't remodel products except by the company's engineers.
  - There may be the possibility of fire or electric shock.
5. Be sure to check input power source options, and connect after checking terminal number when connecting power sources.
  - There may be the possibility of fire.
6. Don't touch the terminal of load side immediately after power source is cut off.
  - There may be the possibility of electric shock.

### ⚠ 주의

1. 실외에서 사용하지 마십시오.
  - 제품의 수명이 짧아지는 원인이 되어 감전의 우려가 있습니다.
2. 전원 및 부하배선 연결 시에는 부하전류에 따른 전선의 굵기에 유의하여 주십시오.
  - 전류에 비하여 전선의 굵기가 가늘면 화재의 위험이 있습니다.
3. 단자대의 나사는 규정토크로 조여 주십시오.
 

규정토크(TORQUE) M3.5: 0.6~1.2N(6~12kgf.cm), M4 : 1.3~1.5 N(10~14Kgf.cm), M5: 2.1~3.0N(21~30kgf.cm), M8:10.6~12.5N(108~127kgf.cm), M12: 35.7~42N(364~428kgf.cm) M14: 57.8~68N(590~693kgf.cm)

  - 나사가 풀리면 접촉불량으로 화재의 우려가 있습니다.
4. 반드시 정격과 성능 범위내에서 사용하여 주십시오.
  - 제품의 수명이 단축되고 고장 발생의 원인이 됩니다.
5. 청소시 물, 유기용제 등의 사용을 금합니다.
  - 감전 및 화재와 제품변형의 우려가 있습니다.
6. 가연성가스, 폭발성가스, 습기, 직사광선, 복사열, 진동, 충격이 있는 장소에서의 설치 및 운전을 금합니다.
  - 제품수명단축 및 고장, 화재, 폭발의 위험이 있습니다.
7. 제품의 내부로 먼지나 배선찌꺼기 등의 유해한 도체가 유입되지 않도록 하여 주십시오.
  - 고장 및 화재의 우려가 있습니다.
8. 제품 사용시 환기되지 않는 밀폐된 곳에서 사용하지 마십시오.
9. 동작 중 방열판류에는 고열이 발생하므로 절대 만지지 마십시오.
  - 감전 및 화상의 우려가 있습니다.
10. 제품폐기 시에는 산업폐기물로서 처리하여 주십시오.

### ⚠ Caution

1. Don't use outdoors (for outdoor, separate order)
  - It can be a cause of product's life becoming short, and there may be the possibility of electric shock.
2. When connecting power source and load wiring, pay attention to the thickness of cables according to load current.
  - There may be the danger of fire if the thickness of cables is small for the current.
3. Tighten the screw of port by the regulated torque.
 

The regulated torque - M3.5 : 0.6~1.2N(6~12kgf.cm), M4 : 1.3~1.5 N(10~14Kgf.cm), M5 : 2.1~3.0N(21~30kgf.cm) M8 : 10.6~12.5N(108~127kgf.cm), M12 : 35.7~42N(364~428kgf.cm), M14 : 57.8~68N(590~693kgf.cm)

  - If the screw comes loose, there may be the possibility of fire because of bad contact.
4. Be sure to use within the range of rating and performance.
  - Product's life is shortened, and it may be a cause of troubles.
5. Don't use water or organic solvent when cleaning.
  - There may be the possibility of electric shock, fire and product deformation.
6. Don't install or operate in places with inflammable gas, explosive gas, direct ray of light, radiation heat, vibration and shock.
  - There may be the possibility of troubles and fire.
7. Make sure that harmful conductors such as dust or fragments of cables may not be flowed into the inside of product.
  - There may be the possibility of trouble or fire.
8. Don't use this product where closed and not ventilated place
  - It may cause a fire and the damage to product.
9. Never touch during operation as there is superheat on the radiator board.
10. Dispose as industrial waste when discarding products.

NCT 노이즈컨트롤박스

REACTOR 리액터

TRANSFORMER 트랜스포머

AHF 호퍼형필터

PHF 수평형필터

MSF 마이크로서지필터

ZHF 영상고조파필터

● Standard :KS C 1706, IEC 61869-2, JEC 1201, IEEE C 57.13



● General Specification

· Operating Temperature -10℃ 55℃ · Humidity 80% RH · 계기용 및 계전기용 Metering or relay · 옥내형 Indoor type · Color: Black

### ● Metering Type

	WY → (WOONYOUNG) C → Current W → winding Terminal Type (권선형)	WY C W — 15	Type : 15
	C → Current Transformer B → Busbar & winding Type(권선형)	WY C B — 151	Type : 151, 152, 153
	C → Current Transformer R → Round Type (환형)	WY C R — 15	Type : 15, 27, 30, 40, 60
	C → Current Transformer S → Square Type(각형)	WY C S — 32	Type : 32, 42, 45, 44, 64, 65, 85, 104, 130, 160
	C → Current Transformer S → Square Type(각형)	WY C S — 125	Type : 125, 135, 137, 165, 167
	C → Current Transformer S → Square Type(각형)	WY C S — 066 MV	MV : Metering Vertical Type MH : Metering Horizontal Type Type : 066, 107, 116, 166, 196
	3C → 3φ Current Transformer S → 3phase Square Type (3상 조합형)	WY 3C S — 16 2 S	2 : 2CT TYPE 3 : 3CT TYPE Type : 16, 26, 31, 46 S : Slim type
	S → Split Type (분할형) C → Current Transformer	WY S C — 23	Type : 23, 58, 88, 812, 816

### ● Protection Relay Type

	WY → (WOONYOUNG) C → Current Transformer S → Square Type(각형)	WY C S — 64 R	Relay Type Type : 64, 104, 130, 160
	C → Current Transformer S → Square Type(각형)	WY C S — 125 R	Relay Type Type : 125, 135, 137, 165, 167
	C → Current Transformer S → Square Type(각형)	WY C S — 066 RV	RV : Relay Vertical Type RH : Relay Horizontal Type Type : 066, 107, 116, 166, 196

### ● 2 Core Type

	C → Current Transformer S → Square Type(각형)	WY C S — 066 WV	WV : 2Core Vertical Type WH : 2Core Horizontal Type Type : 066, 107, 116, 166, 196
---	--	-----------------	--

\* 계기용/계기용, 계기용/계전기용, 계기용/PX 계전기용/계전기용, 계전기용/PX, PX/PX  
( METERING/METERING ), ( METERING/RELAY ), ( METERING/PX ), ( RELAY/RELAY ), ( RELAY/PX ), ( PX/PX )

# ROUND TYPE (환형) CURRENT TRANSFORMER

0.72~1.2kV (50~1500A)



- Standard :KS C 1706, IEC 61869-2, JEC 1201, IEEE C 57.13

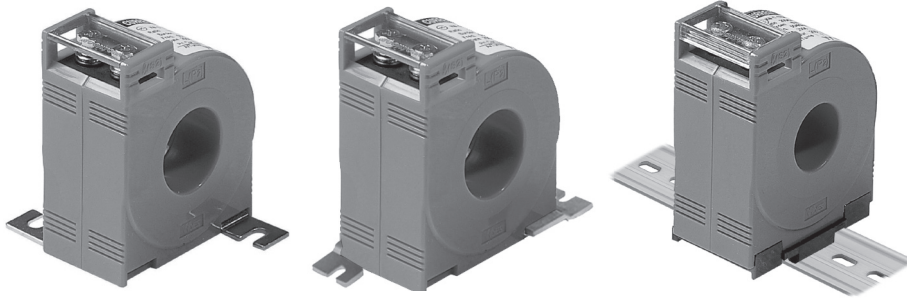

CR "A" TYPE

CR "B" TYPE

Din-Rail

### ● Specifications

- Ring type C,T
- Maximum voltage : 0.72~1.2kV
- Over current strength : 40In/1sec.
- Frequency : 50Hz or 60Hz
- Standard : CR "A" Type
- Option : CR "B" Type, Din-Rail Type

### ● Features

- Protect cover
- Easy to install panel mounting kit
- DIN rail mounting for ease of installation

### ● Specifications

Model	Primary (A)	Secondary (A)	Burden (VA)	Class (%)	Weight (kg)	Hole size (φ)
WYCR-15	50~75	5 or 1	2.5	1.0	≒0.5	15
	100~200		5	1.0	≒0.6	
WYCR-27	50~80		2.5	3.0	≒0.5	27
	80		2.5	1.0		
	100		5	3.0		
	100		5	1.0		
WYCR-30	50~75		2.5	3.0	≒0.4	30
	100~300		5	3.0		
	100~300		5	1.0		
	200~300		15	1.0		
WYCR-40	200~600		5	1.0	≒0.3	40
	400~600		15	1.0		
WYCR-60	100~1500	5	1.0	≒1.0	60	
	200~1500	15	1.0			
	400~1500	40	1.0			

### ● Connection Diagram

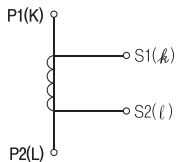

### ● Dimension

unit : (mm)

Model	A	B	C	D	E	F	H	TYPE
WYCR-15, 27, 30, 40	60	76	39	70	60	50	84	A
WYCR-60	60	76	57	114	60	80	112	
WYCR-15, 27, 30, 40	22	46	39	70	22	83	84	B

트랜스포머  
= NCT  
리액터  
= REACTOR  
무전선릴레이  
= SSR  
전력조정기  
= TPR  
스위칭파워  
= SPS  
노이즈필터  
= N/F  
하모닉필터  
= H/F  
서지보호기  
= SPD  
보호계전기  
= RELAY  
누전경보기  
= ELD = GFR  
영상변류기  
= ZCT  
판넬메타  
= METER  
계기용변성기  
= CT = VIT  
선트팬  
= SHUNT = FAN

# ROUND TYPE (환형) CURRENT TRANSFORMER

0.72~1.2kV (5~30A)

● Illustration & Drawing

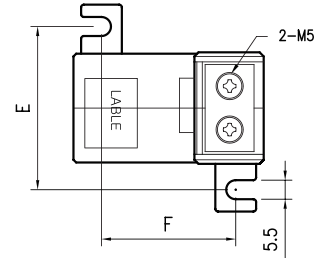
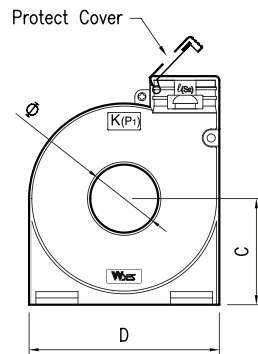
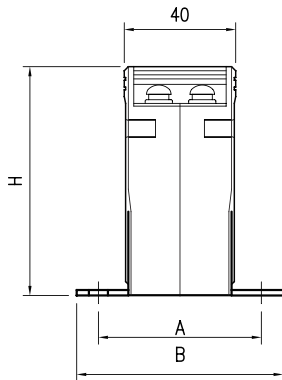

CR "A" TYPE - 15, 27, 30, 40

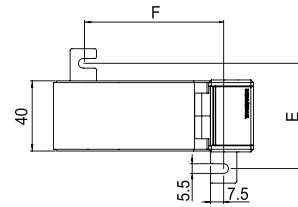
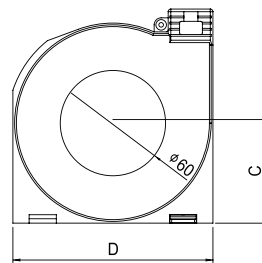
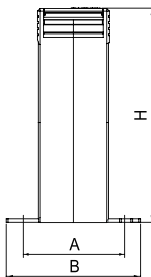

CR "A" TYPE - 60

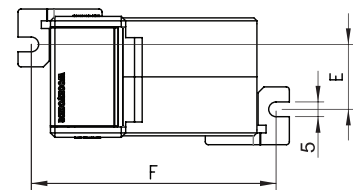
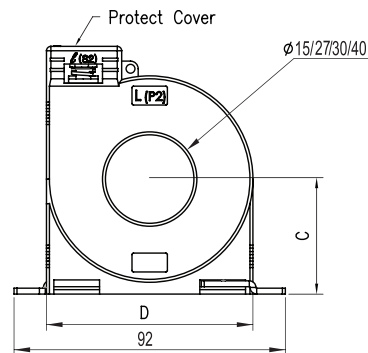
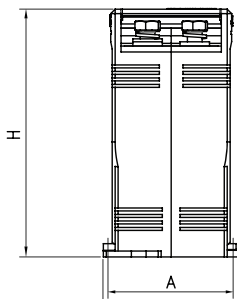

CR "B" TYPE - 15, 27, 30, 40

# ROUND TYPE (환형) CURRENT TRANSFORMER



0.72~1.2kV (5~1500A)



## ● Primary Turns

Model	WYCR-15				WYCR-27, 30						WYCR-40				WYCR-60					
Class	1.0%				3.0%		1.0%				1.0%				1.0%					
Burden	2.5VA		5VA		5VA		5VA		15VA		5VA		15VA		5VA		15VA		40VA	
A/T Pri.	A/T	Tur.	A/T	Tur.	A/T	Tur.	A/T	Tur.	A/T	Tur.	A/T	Tur.	A/T	Tur.	A/T	Tur.	A/T	Tur.	A/T	Tur.
5A	50	10	75	15	100	20	100	20	-	-	200	40	-	-	-	-	-	-	-	-
10A	50	5	80	8	100	10	100	10	-	-	200	20	-	-	-	-	-	-	-	-
15A	60	4	75	5	120	8	120	8	240	16	240	16	-	-	-	-	-	-	-	-
20A	60	3	80	4	100	5	100	5	200	10	200	10	-	-	-	-	-	-	-	-
25A	50	2	75	3	100	4	100	4	200	8	200	8	-	-	-	-	-	-	-	-
30A	60	2	120	4	120	4	120	4	240	8	240	8	-	-	-	-	-	-	-	-
40A	-	-	80	2	120	3	120	3	200	5	240	6	-	-	-	-	-	-	-	-
50A	50	1	100	2	100	2	100	2	200	4	200	4	-	-	-	-	-	-	-	-
60A	60	1	120	2	120	2	120	2	240	4	240	4	-	-	-	-	-	-	-	-
75A	-	-	75	1	75	2	150	2	225	3	200	4	-	-	-	-	-	-	-	-
80A	-	-	80	1	80	3	240	3	240	3	240	3	-	-	-	-	-	-	-	-
100A	-	-	100	1	100	1	100	1	200	2	200	2	-	-	100	1	-	-	-	-
120A	-	-	120	1	100	1	100	1	240	2	240	2	-	-	120	1	-	-	-	-
150A	-	-	150	1	150	1	150	1	300	2	300	2	-	-	150	1	-	-	-	-
200A	-	-	200	1	200	1	200	1	200	1	200	1	-	-	200	1	200	1	-	-
240A	-	-	-	-	240	1	200	1	240	1	240	1	-	-	240	1	240	1	-	-
250A	-	-	-	-	250	1	200	1	250	1	250	1	-	-	250	1	250	1	-	-
300A	-	-	-	-	300	1	200	1	300	1	300	1	300	1	300	1	300	1	-	-
400A	-	-	-	-	-	-	-	-	-	-	400	1	400	1	400	1	400	1	400	1
500A	-	-	-	-	-	-	-	-	-	-	500	1	500	1	500	1	500	1	500	1
600A	-	-	-	-	-	-	-	-	-	-	600	1	600	1	600	1	600	1	600	1
750A	-	-	-	-	-	-	-	-	-	-	-	-	-	750	1	750	1	750	1	
800A	-	-	-	-	-	-	-	-	-	-	-	-	-	800	1	800	1	800	1	
1000A	-	-	-	-	-	-	-	-	-	-	-	-	-	1000	1	1000	1	1000	1	
1200A	-	-	-	-	-	-	-	-	-	-	-	-	-	1200	1	1200	1	1200	1	
1500A	-	-	-	-	-	-	-	-	-	-	-	-	-	1500	1	1500	1	1500	1	

## ● CT(VA)에대한 필요 전선 길이

CT 2차 전선굵기 (mm <sup>2</sup> )	CT 용량(VA)에대한 필요 전선 길이							
	CT 2차 / 5A에대한 용량(VA)							
	1m	2m	4m	6m	8m	10m	15m	20m
2×0.5	1,837	3,67	7,35	11,02	-	-	-	-
2×0.75	1,235	2,47	4,94	7,41	9,88	-	-	-
2×1.0	0,918	1,84	3,67	5,51	7,34	9,18	-	-
2×1.5	0,613	1,23	2,45	3,68	4,90	6,13	9,20	-
2×2.5	0,368	0,74	1,47	2,21	2,94	3,68	5,52	7,36
2×4.0	0,233	0,47	0,93	1,40	1,86	2,33	3,50	4,66
2×6.0	0,149	0,30	0,60	0,89	1,19	1,49	2,23	2,98

TRANS=NECT  
리액터  
무정전블레이  
전력조정기  
스위칭파워  
노이즈필터  
하모닉필터  
서지보호기  
보호계전기  
누전경보기  
영상변류기  
판넬메타  
계기용변성기  
선트팬

# ROUND TYPE ( 환형 - NCT ) CURRENT TRANSFORMER

0.72~1.2kV (100~2000A) 중성선, 보호계전기용 변류기 (Neutral Current Transformer)



- Standard :KS C 1706, IEC 61869-2, JEC 1201, IEEE C 57.13



### ● Specifications

- Ring type C.T
- Maximum voltage : 0.72~1.2kV
- Over current strength : 40In/1sec.
- Frequency : 50Hz or 60Hz
- Insulation : Epoxy vacuum molding

### ● Features

- Protect cover
- Easy to install panel mounting kit
- DIN rail mounting for ease of installation

### ● Specifications

Model	Primary (A)	Class (%)	Burden (VA)	n >	Hole Size (mm)	Weight (kg)
WYCR-65	100~2000/5	1.0	5	-	65	≒14
	100~2000/5		15	-		
	450~2000/5		40	-		
WYCR-65R	100~2000/5	5P	5	10		
	400~2000/5		15	20		
	400~2000/5		40	10		

### • Connection Diagram

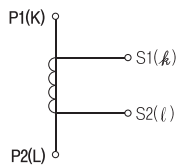

### • Neutral Connection

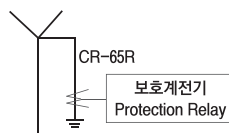

### ● Illustration & Drawing

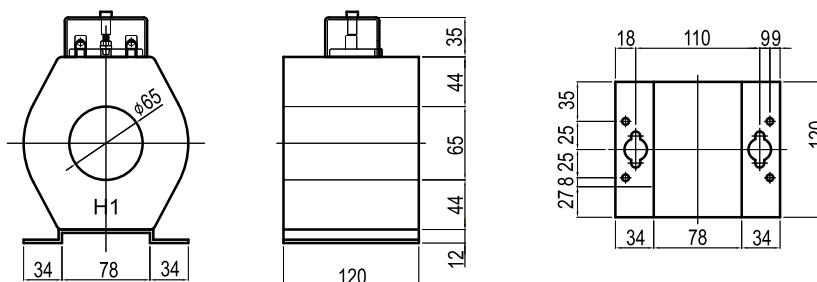



# WINDING TYPE (권선형) CURRENT TRANSFORMER

0.72~1.2kV (5~30A)



- Standard :KS C 1706, IEC 61869-2, JEC 1201, IEEE C 57.13

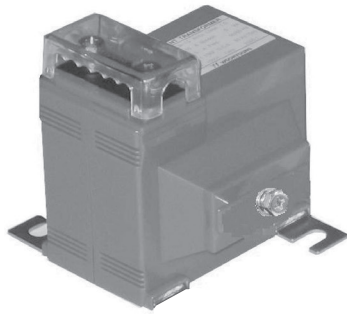

### ● Specifications

- Winding type
- Maximum voltage : 0.72~1.2kV
- Over current strength : 40In/1sec.
- Frequency : 50Hz or 60Hz
- Standard : CR "A" Type
- Option : CR "B" Type

### ● Features

- Protect cover
- Easy to install panel mounting kit

### ● Single Ratio Type

Model	Primary (A)	Secondary (A)	Burden (VA)	Class (%)	Weight (kg)
WYCW-15	5~30	5 or 1	15	1.0	≒0.7

### ● Double Ratio Type

Model	Primary (A)	Secondary (A)	Burden (VA)	Class (%)	Weight (kg)
WYCW-15D	10~30 (5~15)	5 or 1	15	1.0	≒0.7

※ Apply rated current burden to  $\frac{1}{2}$  tap

### ● Connection Diagram

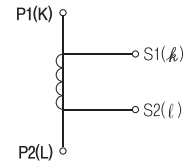

### ● Illustration & Drawing

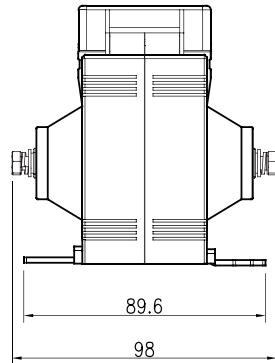
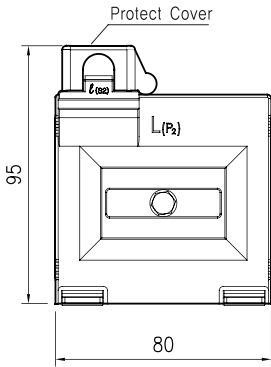

CW "A" TYPE

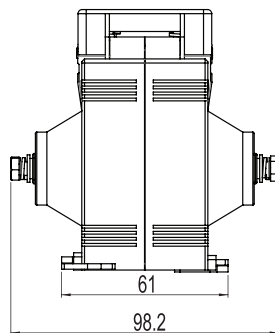
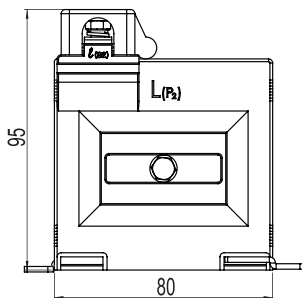
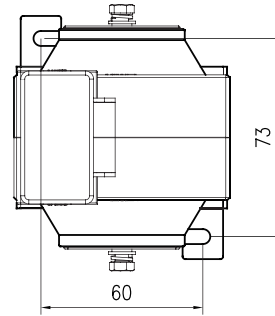

CW "B" TYPE

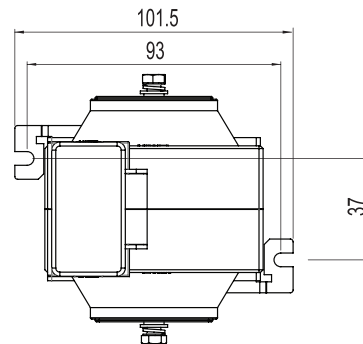

트랜스포머  
REACTOR  
리액터  
무전압분류  
SSR  
전력조정기  
TPR  
스위칭파워  
SMP  
노이즈필터  
N/F  
하모닉필터  
H/F  
서지보호기  
SPD  
보호계전기  
RELAY  
누전경보기  
ELD-GFR  
영상변류기  
ZCT  
판넬메타  
METER  
계기용변성기  
CT-VT  
선풍팬  
SHUNT-FAN

# WINDING TYPE (권선형) CURRENT TRANSFORMER

0.72~1.2kV (5~500A)



- Standard :KS C 1706, IEC 61869-2, JEC 1201, IEEE C 57.13

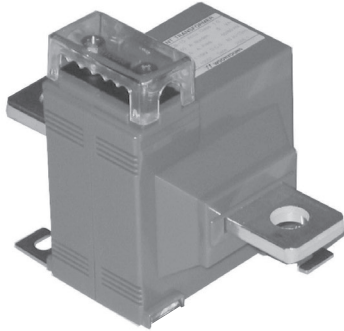

### ● Specifications

- busbar type
- Maximum voltage : 0.72~1.2kV
- Over current strength : 40In/1sec.
- Frequency : 50Hz or 60Hz
- Case : Poly carbonate (PC)
- Standard : CR "A" Type
- Option : CR "B" Type

### ● Features

- Protect cover
- Easy to install panel mounting kit

### ● Single Ratio Type

Model	Primary (A)	Secondary (A)	Burden (VA)	Class (%)	Weight (kg)
WYCB-151	5~150	5 or 1	5~15	1.0	≒0.5
WYCB-152	200~300				≒0.6
WYCB-153	400~500				≒0.7

### ● Connection Diagram

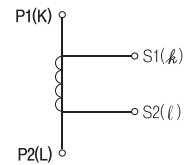

### ● Double Ratio Type

Model	Primary (A)	Secondary (A)	Burden (VA)	Class (%)	Weight (kg)
WYCB-151D	10~150 (5~75)	5 or 1	5~15	1.0	≒0.5
WYCB-152D	200~300 (100~150)				≒0.6
WYCB-153D	400~500 (200~250)				≒0.7

※ Apply rated current burden to 1 tap

### ● Dimension

unit : (mm)

Model	A	B	C	T	∅
WYCB-151/151D	110	135	25	3	10
WYCB-152/152D	115	145	30	6	13
WYCB-153/153D	120	150	40	8	13

### ● Illustration & Drawing

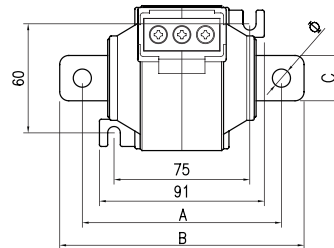
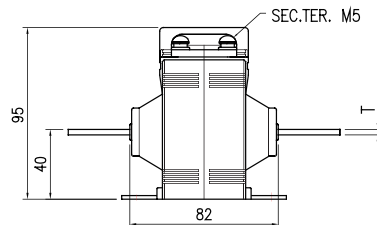
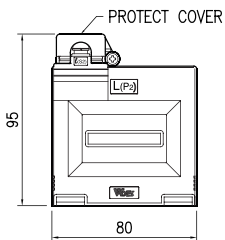

CB "A" TYPE

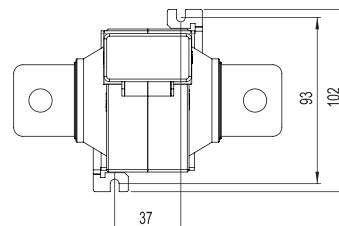
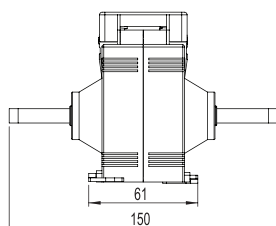
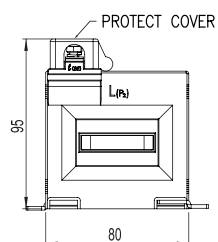

CB "B" TYPE

# PANEL INSTALLING TYPE (부스바 및 케이블관통형) CURRENT TRANSFORMER

**WYES**  
계기용변성기

0.72~1.2kV (400~2000A)



- Standard :KS C 1706, IEC 61869-2, JEC 1201, IEEE C 57.13

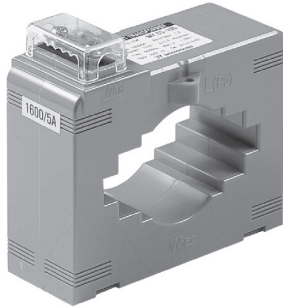

## ● Specifications

- Square type C.T(Panel installing type)
- Maximum voltage : 0.72~1.2kV
- Over current strength : 40In/1sec.
- Frequency : 50Hz or 60Hz
- Case : Poly carbonate (PC)

## ● Features

- Protect cover
- Easy to install panel mounting kit

## ● Single Ratio Type

Model	Primary (A)	Secondary (A)	Burden (VA)	Class (%)	Weight (kg)
WYCS-105	400~2000	5 or 1	15	1.0	≒1.2

## ● Double Ratio Type

Model	Primary (A)	Secondary (A)	Burden (VA)	Class (%)	Weight (kg)
WYCS-105D	800/400	5 or 1	15	1.0	≒1.2
	1000/500				
	1200/600				
	1500/750				
	2000/1000				

## ● Illustration & Drawing

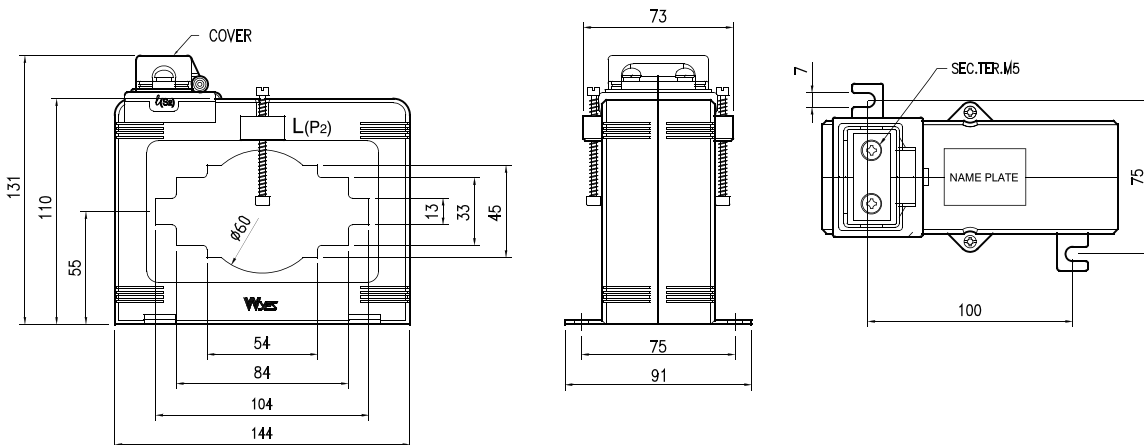

## ● Connection Diagram

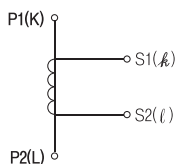

**T**랜스포머  
**R**ANS=INCT  
**R**리액터  
**E**CTOR  
**S**무선전송용 레이  
**S**SSR  
**T**전력조정기  
**P**TPR  
**R**스위칭용 파워  
**S**MPS  
**N**노이즈 필터  
**F**N/F  
**H**하모닉 필터  
**F**H/F  
**S**서지보호기  
**P**SPD  
**R**보호계전기  
**E**RELA  
**L**누전경보기  
**D**LD=GF  
**F**FR  
**Z**영상변류기  
**C**ZCT  
**M**판넬메타  
**E**METER  
**R**계기용 변성기  
**C**CT=VT  
**T**CT=VT  
**S**선트팬  
**H**SHUNT=FA  
**N**T=FA  
**F**FAN

# METERING TYPE (부스바 관통형 / 계기용) CURRENT TRANSFORMER

0.72~1.2kV (100~5000A)



- Standard :KS C 1706, IEC 61869-2, JEC 1201, IEEE C 57.13



### ● Specifications

- Square type C,T(Busbar installing type)
- Maximum voltage : 0,72~1,2kV
- Over current strength : 40In/1sec.
- Frequency : 50Hz or 60Hz
- Case : Poly carbonate (PC)
- Standard : CR "A" Type
- Option : CR "B" Type

### ● Features

- Protect cover
- Easy to install panel mounting kit

### ● Connection Diagram

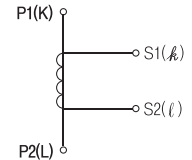

### ● Single Ratio Type

Model	Primary (A)	Secondary (A)	Burden (VA)	Class (%)	Weight (kg)
WYCS-32	100~300	5 or 1	5	1.0	≒0.5
	200~300		15		
WYCS-42	200~400		5		≒0.5
	400		15		
WYCS-45	200~750		5		≒0.5
	400~750		15		
WYCS-44	100~300		5		≒0.9
	200~300		15		
WYCS-65	250~600		5		≒0.7
	400~600		15		
	500~600		40		
WYCS-64	100~600		5		≒2.2
	150~600		15		
	200~600		40		
WYCS-85	500~1200		15		≒0.8
	600~1200		40		
WYCS-104	800~2500	15 or 40	≒1.8		
WYCS-130	1200~3000	15 or 40	≒2.0		
WYCS-160	1200~5000	15 or 40	≒3.6		

### ● Dimension

unit : (mm)

Model	H-1	H	W-1	W	E	TYPE
WYCS-32	7	77	32	67	11	A
WYCS-42	7	77	42	67	11	A
WYCS-45	10	77	45	67	11	A
WYCS-44	11	60	44	97	18	B
WYCS-65	11	65	65	124	18	B
WYCS-64	12	91	64	140	21	B
WYCS-85	13	65	85	124	18	B
WYCS-104	30	102	104	170	21	B
WYCS-130	40	112	130	208	21	B
WYCS-160	65	153	160	246	21	B

# METERING TYPE (부스바 관통형 / 계기용) CURRENT TRANSFORMER

0.72~1.2kV (100~5000A)

**WYES**  
계기용변성기



● Illustration & Drawing

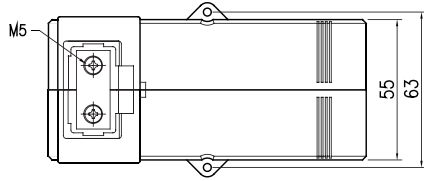

CS "A", "B" Standard

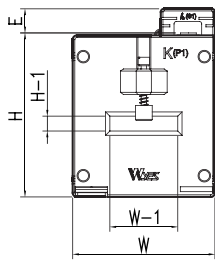

CS "A" TYPE

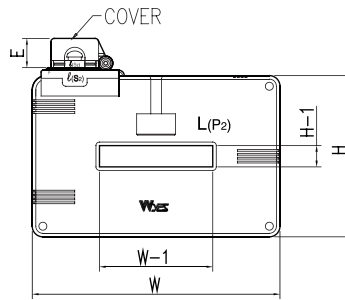
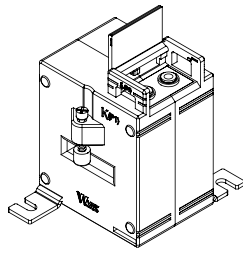

CS "B" TYPE

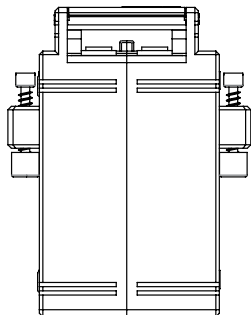
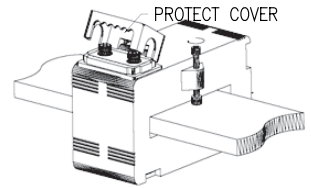

CS "A" Standard

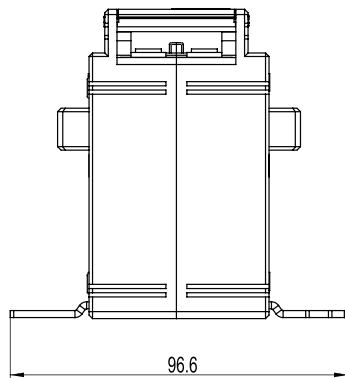

CS "A" Option 1

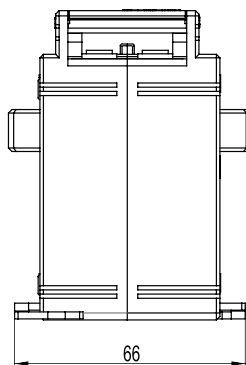
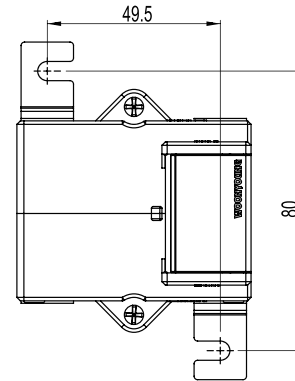

CS "A" Option 2

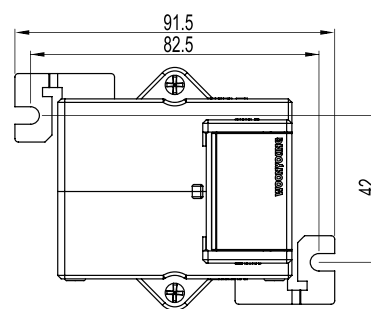

트랜스포머  
REACTOR  
리액터  
무전선변류기  
SSR  
전력조정기  
TPR  
스위칭파워  
SMP  
노이즈필터  
N/F  
하모닉필터  
H/F  
서지보호기  
SPD  
보호계전기  
RELAY  
E  
LD = GFR  
누전경보기  
영상변류기  
ZCT  
판넬메타  
METER  
계기용변성기  
CT = VTI  
S  
HUNT = FAN  
선트팬

# PROTECTION RELAY TYPE (부스바관통형/ 보호계전기용) CURRENT TRANSFORMER

0.72~1.2kV (150~5000A)



- Standard :KS C 1706, IEC 61869-2, JEC 1201, IEEE C 57.13

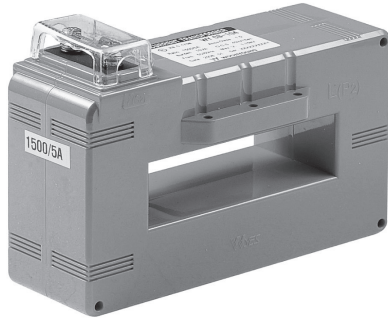

### ● Specifications

- Square type C.T(Panel installing type)
- Maximum voltage : 0.72~1.2kV
- Over current strength : 40In/1sec.
- Frequency : 60Hz (Option 50Hz)
- Case : Poly carbonate (PC)

### ● Features

- Protect cover
- Easy to install panel mounting kit

### ● Illustration & Drawing

Protect Cover

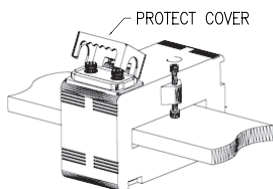
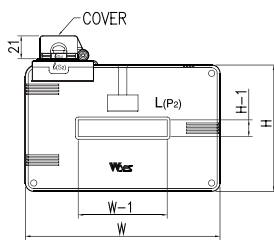
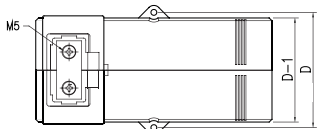

### ● Single Ratio Type

Model	Primary (A)	Secondary (A)	Class (%)	Burden (VA)	n )	Weight (kg)
WYCS-64R	150~800	5 or 1	5P(IEC)	5	10	≒2.5
	400~800			5	20	≒2.2
	400~800			15	10	≒2.2
WYCS-104R	150~2000			5	10	≒3.3
	400~2000			5	20	≒3.3
	400~2000			15	10	≒3.3
WYCS-130R	400~3000			5	10	≒2.3
	1200~3000			5	20	≒2.3
	1000~3000			15	10	≒2.3
WYCS-160R	200~5000	5	10	≒3.6		
	1000~5000	5	20	≒3.6		
	600~5000	15	10	≒3.6		
	2000~5000	15	20	≒3.6		

### ● Dimension

unit : (mm)

Model	H-1	H	W-1	W	D-1	D
WYCS-64R	12	91	64	140	75	83
WYCS-104R	25	97	104	170	75	83
WYCS-130R	40	112	130	208	55	63
WYCS-160R	65	153	160	246	55	63

### • Connection Diagram

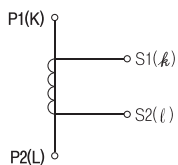

# METERING TYPE (부스바 관통형 / 계기용) CURRENT TRANSFORMER

**WYES**  
계기용변성기

0.72~1.2kV (1200~6000A)



- Standard :KS C 1706, IEC 61869-2, JEC 1201, IEEE C 57.13

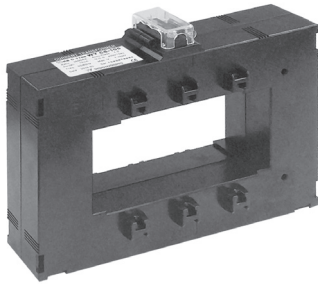

### ● Specifications

- Square type C.T(Busbar installing type)
- Maximum voltage : 0.72~1.2kV
- Over current strength : 40In/1sec.
- Frequency : 50Hz or 60Hz
- Case : Poly carbonate (PC)

### ● Features

- Protect cover
- Easy to install panel mounting kit

### ● Illustration & Drawing

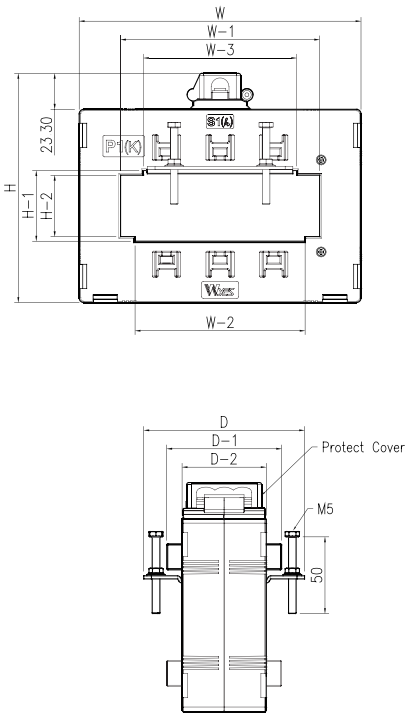

### ● Single Ratio Type

Model	Primary (A)	Secondary (A)	Burden (VA)	Class (%)	Weight (kg)
WYCS-125	1200	5 or 1	15, 40	0.5 or 1	≈3.0
	1500				
	2000				
WYCS-135	2500				
	3000				
	3200				
	3500				
WYCS-165	4000				
	2500				≈3.8
	3000				
	3200				
	4000	≈4.1			
	5000				
6000					

### ● Dimension

unit : (mm)

Model	W	W-1	W-2	W-3	H	H-1	H-2	H-3	D	D-1
WYCS-125	184	130	111	100	149,5	46	40	23,5	75	55
WYCS-135	185,4	134,6	109,6	98,6	177,2	59,6	53,6	23,5	75	55
WYCS-165	256,4	158,6	134,6	108,6	199,2	80,6	74,6	23,8	75	55

### ● Connection Diagram

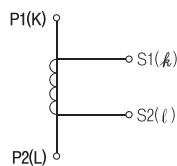

**T R A N S = N C T** 트랜스포머  
**R E A C T O R** 리액터  
**S S R** 무정전블레이  
**T P R** 전력조정기  
**S M P S** 스위칭파워  
**N / F** 노이즈 필터  
**H / F** 하모닉 필터  
**S P D** 서지보호기  
**R E L A Y** 보호계전기  
**E L D = G F R** 누전경보기  
**Z C T** 영상변류기  
**M E T E R** 판넬메타  
**C T = V T** 계기용변성기  
**S H U N T = F A N** 셉트팬

# PROTECTION RELAY TYPE (부스바관통형/보호계전기용) CURRENT TRANSFORMER

0.72~1.2kV (1200~6000A)



- Standard :KS C 1706, IEC 61869-2, JEC 1201, IEEE C 57.13

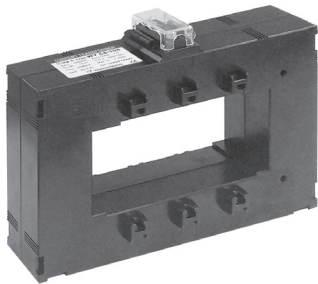

### ● Specifications

- Square type C.T(Busbar installing type)
- Maximum voltage : 0.72~1.2kV
- Over current strength : 40In/1sec.
- Frequency : 60Hz (Option 50Hz)
- Case : Poly carbonate (PC)

### ● Features

- Protect cover
- Easy to install panel mounting kit

### ● Illustration & Drawing

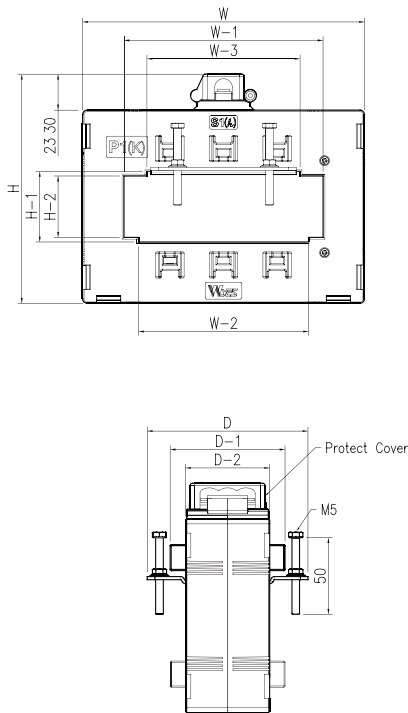

### ● Single Ratio Type

Model	Primary (A)	Secondary (A)	Burden (VA)	Class (%)	Weight (kg)			
WYCS-125R	1200	5 or 1	15	5P10	≈3.2			
	1500							
	2000							
WYCS-135R	2500					10	5P10	≈3.2
	3000							
	3200							
WYCS-137R	3500		15	5P10	≈3.6			
	4000							
	4000							
WYCS-165R	2500		10	5P10	≈3.8			
	3000							
	3200							
	3500	≈4.1						
	4000							
	5000							
WYCS-167R	6000	15	5P10	≈4.0				
	2500							
	3000							
	3200							
	3500			≈4.5				
	4000	15 (40)	5P10, 5P20 (5P10)					
	5000							

### ● Connection Diagram

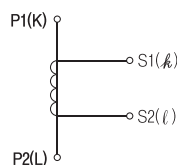

### ● Dimension

unit : (mm)

Model	W	W-1	W-2	W-3	H	H-1	H-2	H-3	D	D-1
WYCS-125R	184	130	111	100	149.5	46	40	23.5	75	55
WYCS-135R	185.4	134.6	109.6	98.6	177.2	59.6	53.6	23.5	75	55
WYCS-137R	185.4	134.6	109.6	98.6	177.2	59.6	53.6	22.8	95	75
WYCS-165R	256.4	158.6	134.6	108.6	199.2	80.6	74.6	23.8	75	55
WYCS-167R	256.4	158.6	134.6	108.6	199.2	80.6	74.6	23.8	94.4	75



# METERING TYPE (부스바관통형/계기용) CURRENT TRANSFORMER



계기용변성기

0.72~1.2kV (150~7000A)



- Standard :KS C 1706, IEC 61869-2, JEC 1201, IEEE C 57.13

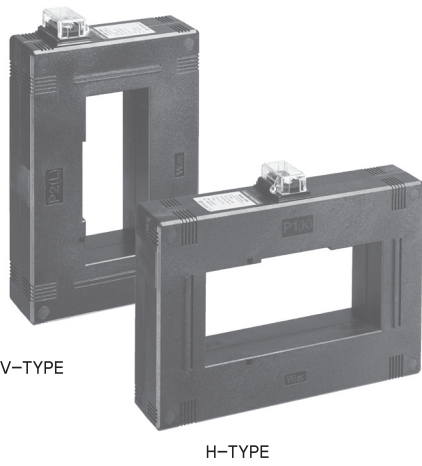

V-TYPE

H-TYPE

## ● Specifications

- Square type C,T(Busbar installing type)
- Maximum voltage : 0.72~1.2kV
- Over current strength : 40In/1sec.
- Frequency : 60Hz (Option 50Hz)
- Case : Poly carbonate (PC)

## ● Features

- Protect cover
- Easy to install panel mounting kit

## ● 1-Core Single Ratio Type

Model	Primary (A)	Secondary (A)	Burden (VA)	Class	weight (kg)			
WYCS-066MV WYCS-066MH	150~630	5 or 1	5VA	1.0	4.5			
	400~630			1.0	4.5			
	500~630			1.0	4.5			
WYCS-105MV WYCS-105MH	300~2000		5 or 1	15VA	1.0	4.5		
	300~2000				1.0	5		
	500~2000				1.0	5		
WYCS-107MV WYCS-107MH	150~1200			5 or 1	5VA	1.0	6	
	200~1200					1.0	6	
	300~1200					1.0	6	
WYCS-116MV WYCS-116MH	630~1200				5 or 1	15VA	1.0	6
	750~1200						1.0	6
	1500~3000						1.0	6
WYCS-166MV WYCS-166MH	200~3000	5 or 1				5VA	1.0	6
	400~3000						1.0	6
	600~3000						1.0	6
WYCS-166MV WYCS-166MH	1200~3000		5 or 1			15VA	1.0	6
	1500~3000						1.0	6
	3000~5000						1.0	8
WYCS-196MV WYCS-196MH	3000~5000			5 or 1		5VA	1.0	8
	3000~5000						1.0	8
	3000~5000						1.0	8
WYCS-196MV WYCS-196MH	3000~5000				5 or 1	15VA	1.0	8
	4000~7000						1.0	9
	4000~7000						1.0	9
WYCS-196MV WYCS-196MH	4000~7000	5 or 1				5VA	1.0	9
	4000~7000						1.0	9
	4000~7000						1.0	9
WYCS-196MV WYCS-196MH	4000~7000		5 or 1			15VA	1.0	9
	4000~7000						1.0	9
	4000~7000						1.0	9

\* Please inquire us in advance for the customized-specification ( 0.5 / 0.2 class)

## ● Illustration & Drawing

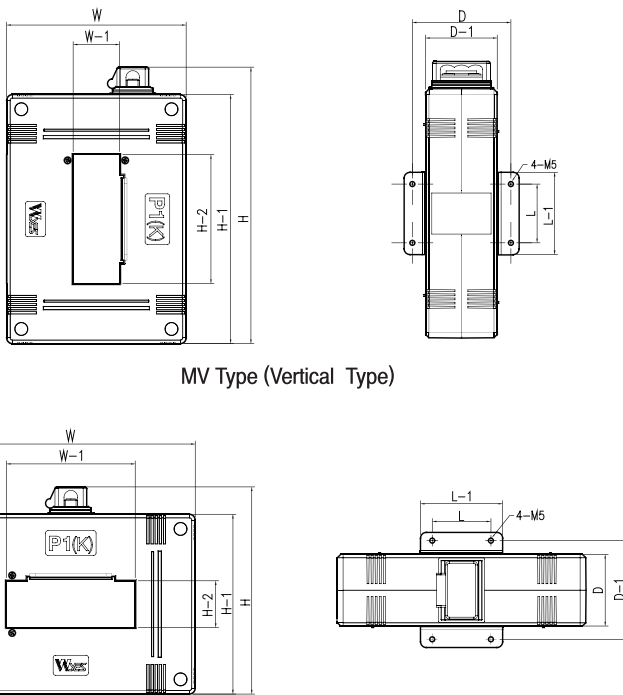

MV Type (Vertical Type)

MH Type (Horizontal Type)

## ● Connection Diagram

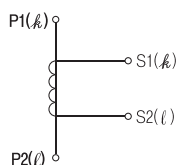

1 - Core Single ratio

## ● Dimension

unit : (mm)

Model	W	W-1	H	H-1	H-2	D	D-1	L	L-1
WYCS-066MV	117	15	179.5	156	61	84	61	20	45
WYCS-066MH	156	61	140.5	117	15	84	61	20	45
WYCS-105MV	148	34.7	227.3	204	101.7	78	55	50	70
WYCS-105MH	204	101.7	171.3	148	34.7	78	55	50	70
WYCS-107MV	148	35	227.5	204	102	97	74	50	70
WYCS-107MH	204	102	171.5	148	35	97	74	50	70
WYCS-116MV	153	40	235.5	212	110	84	61	50	70
WYCS-116MH	212	110	176.5	153	40	84	61	50	70
WYCS-166MV	176	65	283.5	260	160	84	61	50	70
WYCS-166MH	260	160	199.5	176	65	84	61	50	70
WYCS-196MV	199	90	311.5	288	190	84	61	50	70
WYCS-196MH	288	190	222.5	199	90	84	61	50	70

TRANS=NECT  
 리액터  
 REACTOR  
 무정전용량레이  
 SSR  
 전력조정기  
 TPR  
 스위칭파워  
 SMP  
 노이즈필터  
 N/F  
 하모닉필터  
 H/F  
 서지보호기  
 SPD  
 보호계전기  
 RELAY  
 누전경보기  
 ELD=GF  
 영상변류기  
 ZCT  
 판넬메타  
 METER  
 계기용변성기  
 CT=VT  
 섀트팬  
 SHUNT=FA

# PROTECTION RELAY TYPE (부스바관통형/계전기용) CURRENT TRANSFORMER

0.72~1.2kV (150~6000A)



- Standard :KS C 1706, IEC 61869-2, JEC 1201, IEEE C 57.13

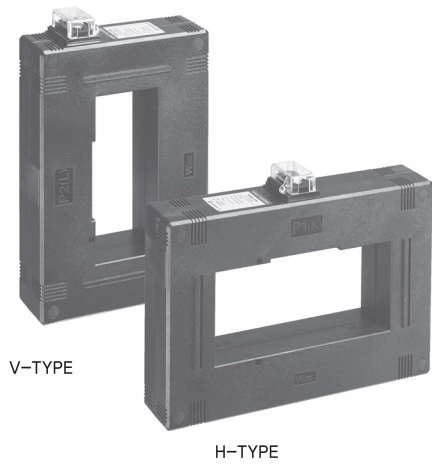

V-TYPE

H-TYPE

## ● Illustration & Drawing

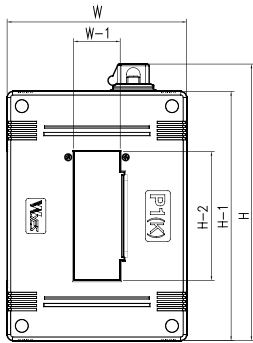

RV Type (Vertical Type)

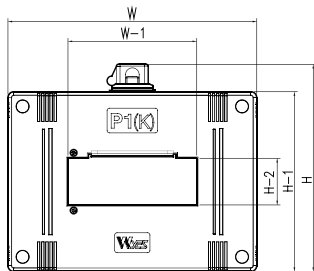
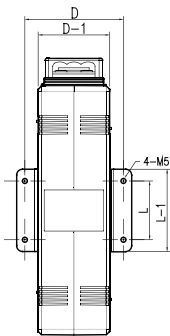

RH Type (Horizontal Type)

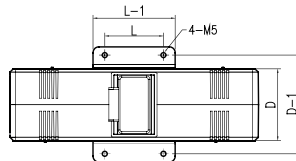

## ● Specifications

- Square type C,T(Busbar installing type)
- Maximum voltage : 0.72~1.2kV
- Over current strength : 40In/1sec.
- Frequency : 60Hz (Option 50Hz)
- Case : Poly carbonate (PC)

## ● Features

- Protect cover
- Easy to install panel mounting kit

## ● 1-Core Single Ratio Type

Model	Primary (A)	Secondary (A)	Burden (VA)	Class	weight (kg)				
WYCS-066RV WYCS-066RH	150~630	5 or 1	5VA	5P10	4.5				
	400~630			5P20	4.5				
	500~630		15VA	5P10	4.5				
WYCS-105RV WYCS-105RH	200~2000		5 or 1	5VA	5P10	5			
	500~2000				5P20	5			
	500~2000			15VA	5P10	5			
	1500~2000			5P20	5				
WYCS-107RV WYCS-107RH	150~1200		5 or 1	5VA	5P10	6			
	200~1200				5P20	6			
	300~1200			15VA	5P10	6			
	630~1200			5P20	6				
WYCS-116RV WYCS-116RH	750~1200			5 or 1	40VA	5P10	6		
	WYCS-166RV WYCS-166RH	200~3000				5 or 1	5VA	5P10	6
		400~3000			5P20			6	
		600~3000			15VA		5P10	6	
1200~3000		5P20			6				
WYCS-166RV WYCS-166RH	1500~3000	5 or 1			40VA	5P10	6		
	WYCS-196RV WYCS-196RH					3000~5000	5 or 1	5VA	5P10
					3000~5000	5P20			8
			3000~5000		15VA	5P10		8	
3000~5000			5P20		8				
WYCS-196RV WYCS-196RH	4000~6000		5 or 1		5VA	5P10	9		
	4000~6000					5P20	9		
	4000~6000			15VA	5P10	9			
	4000~6000			5P20	9				
WYCS-196RV WYCS-196RH	4000~6000			5 or 1	40VA	5P10	9		
	4000~6000					5P10	9		

• Please inquire us in advance for the customized-specification ( PX class)

## ● Connection Diagram

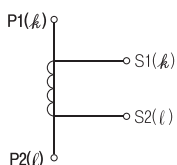

1 - Core Single ratio

## ● Dimension

unit : (mm)

Model	W	W-1	H	H-1	H-2	D	D-1	L	L-1
WYCS-066RV	117	15	179.5	156	61	84	61	20	45
WYCS-066RH	156	61	140.5	117	15	84	61	20	45
WYCS-105RV	148	34.7	227.3	204	101.7	78	55	50	70
WYCS-105RH	204	101.7	171.3	148	34.7	78	55	50	70
WYCS-107RV	148	35	227.5	204	102	97	74	50	70
WYCS-107RH	204	102	171.5	148	35	97	74	50	70
WYCS-116RV	153	40	235.5	212	110	84	61	50	70
WYCS-116RH	212	110	176.5	153	40	84	61	50	70
WYCS-166RV	176	65	283.5	260	160	84	61	50	70
WYCS-166RH	260	160	199.5	176	65	84	61	50	70
WYCS-196RV	199	90	311.5	288	190	84	61	50	70
WYCS-196RH	288	190	222.5	199	90	84	61	50	70

# PROTECTION RELAY TYPE (부스바관통형/계기용및전기용) CURRENT TRANSFORMER

**WYES**  
계기용변성기

0.72~1.2kV (150~6000A)



- Standard :KS C 1706, IEC 61869-2, JEC 1201, IEEE C 57.13

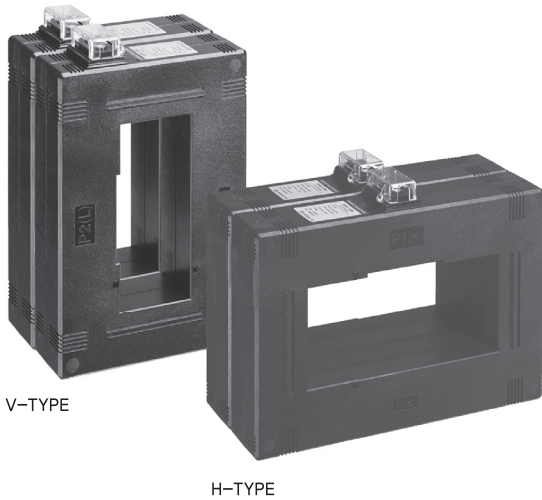

### ● Specifications

- Square type C.T(Busbar installing type)
- Maximum voltage : 0,72~1,2kV
- Over current strength : 40In/1sec.
- Frequency : 60Hz (Option 50Hz)
- Case : Poly carbonate (PC)

### ● Features

- Protect cover
- Easy to install panel mounting kit

### ● 2-Core Single Ratio Type

Model	Primary (A)	Secondary (A)	Burden (VA)	Class	weight (kg)
WYCS-066WV WYCS-066WH	150~630	5 or 1	5/5VA	1,0/5P10	10
	400~630			1,0/5P20	10
	500~630		15/15VA	1,0/5P10	10
WYCS-105WV WYCS-105WH	300~2000		5/5VA	1,0/5P10	10
	500~2000			1,0/5P20	10
	500~2000		15/15VA	1,0/5P10	10
	1500~2000			1,0/5P20	10
	1500~2000			40/40VA	1,0/5P10
WYCS-107WV WYCS-107WH	150~1200		5/5VA	1,0/5P10	14
	200~1200			1,0/5P20	14
	300~1200		15/15VA	1,0/5P10	14
	630~1200			1,0/5P20	14
	750~1200	40/40VA		1,0/5P10	14
WYCS-116WV WYCS-116WH	200~3000	5/5VA	1,0/5P10	14	
	400~3000		1,0/5P20	14	
	600~3000		15/15VA	1,0/5P10	14
	1200~3000		1,0/5P20	14	
WYCS-166WV WYCS-166WH	1500~3000	40/40VA	1,0/5P10	14	
	3000~5000		5/5VA	1,0/5P10	16
	3000~5000			1,0/5P20	16
	3000~5000		15/15VA	1,0/5P10	16
WYCS-196WV WYCS-196WH	3000~5000	40/40VA	1,0/5P10	16	
	4000~6000		5/5VA	1,0/5P10	18
	4000~6000			1,0/5P20	18
	4000~6000		15/15VA	1,0/5P10	18
	4000~6000	40/40VA	1,0/5P20	18	
	4000~6000		1,0/5P10	18	

• Please inquire us in advance for the customized-specification ( PX/PX , Relay/Relay)

### ● Dimension

unit : (mm)

Model	W	W-1	H	H-1	H-2	D	D-1	L	L-1
WYCS-066WV	117	15	179,5	156	61	145	122	20	45
WYCS-066WH	156	61	140,5	117	15	145	122	20	45
WYCS-105WV	148	34,7	227,3	204	101,7	133	110	50	70
WYCS-105WH	204	101,7	171,3	148	34,7	133	110	50	70
WYCS-107WV	148	35	227,5	204	102	171	148	50	70
WYCS-107WH	204	102	171,5	148	35	171	148	50	70
WYCS-116WV	153	40	235,5	212	110	145	122	50	70
WYCS-116WH	212	110	176,5	153	40	145	122	50	70
WYCS-166WV	176	65	283,5	260	160	145	122	50	70
WYCS-166WH	260	160	199,5	176	65	145	122	50	70
WYCS-196WV	199	90	311,5	288	190	145	122	50	70
WYCS-196WH	288	190	222,5	199	90	145	122	50	70

### ● Illustration & Drawing

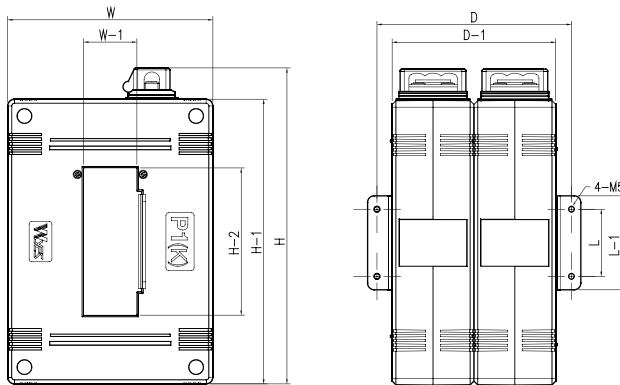

WV Type (Vertical Type)

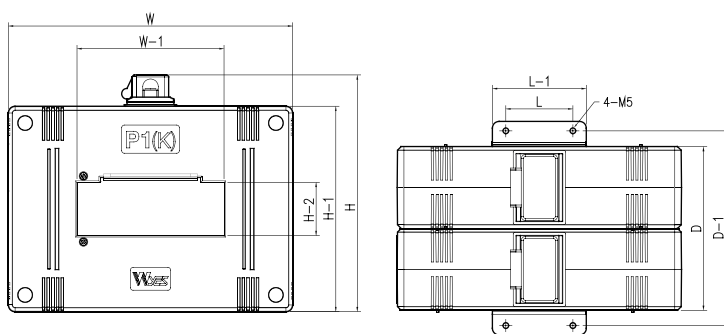

WH Type (Horizontal Type)

### ● Connection Diagram

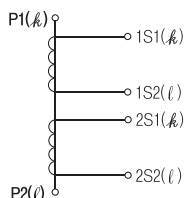

2 - Core Single ratio

TRANS= NCT  
 리액터  
 REACTOR  
 무정전출력레이  
 SSR  
 전력조정기  
 TPR  
 스위칭파워  
 SMP  
 노이즈 필터  
 N/F  
 하모닉 필터  
 H/F  
 서지보호기  
 SPD  
 보호계전기  
 RELAY  
 누전경보기  
 ELD= GFR  
 영상변류기  
 ZCT  
 판넬메타  
 METER  
 계기용변성기  
 CT= VVT  
 섀트팬  
 SHUNT= FAN

# 3PHASE INSTALLING TYPE (3상 일체형) CURRENT TRANSFORMER

0.72~1.2kV (50~1000A)



- Standard :KS C 1706, IEC 61869-2, JEC 1201, IEEE C 57.13

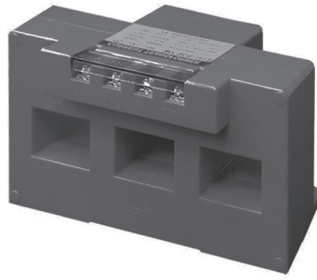

### ● Features

- 3Phase all in one type
- MCCB mixing type
- Square type C,T(Busbar & Cable installing type)
- Maximum voltage : 1150V
- Over current strength : 40In/1sec.
- Frequency : 50Hz or 60Hz
- Secondary current : 5A
- Case : Poly carbonate (PC)

### ● Specifications

#### · 2CT Type

MODEL	MCCB	CT (INPUT)	Primary (A)	Secondary (A)	Class (%)	Burden (VA)	Weight (kg)
WY3CS-162	125AF	2CT TYPE	50~100A	5A	3.0	2.5	0.8
			100~120A		3.0	5	
			100~120A		3.0	15	
WY3CS-262	250AF	2CT TYPE	120~300A		3.0	5	1.1
			200~300A		1.0	5	
			250~300A		1.0	15	
WY3CS-312	400AF	2CT TYPE	250~500A	1.0	15	1.2	
WY3CS-462	630AF	2CT TYPE	500~1000A	1.0	15	2.0	
	800AF						

#### · 3CT Type

MODEL	MCCB	CT (INPUT)	Primary (A)	Secondary (A)	Class (%)	Burden (VA)	Weight (kg)
WY3CS-163	125AF	3CT TYPE	50~100A	5A	3.0	2.5	0.9
			100~120A		3.0	5	
			100~120A		3.0	15	
WY3CS-263	250AF	3CT TYPE	120~300A		3.0	5	1.2
			200~300A		1.0	5	
			250~300A		1.0	15	
WY3CS-313	400AF	3CT TYPE	250~500A	1.0	15	1.4	
WY3CS-463	630AF	3CT TYPE	500~1000A	1.0	15	2.2	
	800AF						

### ● Illustration & Drawing

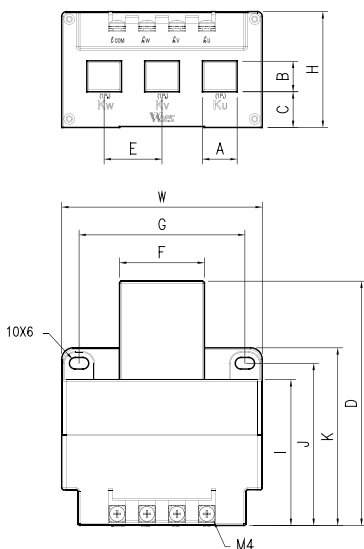

### ● Connection Diagram

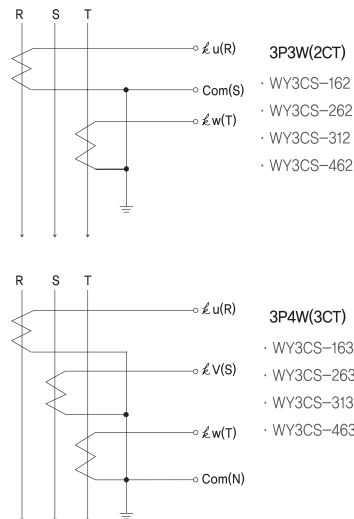

Unit : (mm)

Model	W	H	D	A	B	C	E	F	G	I	J	K
WY3CS-162	104	60	126.5	16	14	19.5	30	44	86	75.5	84	92
WY3CS-163												
WY3CS-262	115	60	126.5	26	21	17.5	35	47	97	75.5	84	92
WY3CS-263												
WY3CS-312	145	85	93	31	24	26	44	57	127	58	66.5	74.5
WY3CS-313												
WY3CS-462	215	95	85	46	32	30	70	77	197	51.5	58.5	66.5
WY3CS-463												

# 3PHASE INSTALLING TYPE (3상 일체형) CURRENT TRANSFORMER

**WYES**  
저압계기용변성기

0.72~1.2kV (50~300A)



- Standard :KS C 1706, IEC 61869-2, JEC 1201, IEEE C 57.13

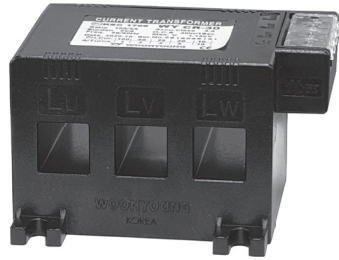

### ● Features

- 3Phase all in one type
- MCCB mixing type
- Square type C.T(Busbar & Cable installing type)
- Maximum voltage : 0.72~1.2kV
- Over current strength : 40In/1sec.
- Frequency : 50Hz or 60Hz
- Secondary current : 5A
- Case : Poly carbonate (PC)

### ● Specification

#### · 2CT Type

MODEL	MCCB	CT (TYPE)	Primary (A)	Secondary (A)	Class (%)	Burden (VA)	Weight (kg)
WY3CS-052S	50~100AF	2CT TYPE	75A	5A	3.0	1.25	0.32
			100A			1.25	0.32
			120A			1.25	0.32
WY3CS-052	50~100AF	2CT TYPE	50A			1.25	0.46
			60A			1.25	0.46
			75A			2.5	0.46
			100A			2.5	0.47
WY3CS-122	125AF	2CT TYPE	120A			2.5	0.47
			150A			2.5	0.49
			100A			2.5	0.49
			200A			5	0.50
			250A			1.25	0.39
WY3CS-252	250AF	2CT TYPE	120A	1.25	0.39		
			150A	2.5	0.39		
			200A	2.5	0.40		
			250A	2.5	0.41		
			300A	2.5	0.42		

#### · 3CT Type

MODEL	MCCB	CT (TYPE)	Primary (A)	Secondary (A)	Class (%)	Burden (VA)	Weight (kg)
WY3CS-053S	50~100AF	3CT TYPE	75A	5A	3.0	1.25	0.42
			100A			1.25	0.42
			120A			1.25	0.42
WY3CS-053	50~100AF	3CT TYPE	50A			1.25	0.59
			60A			1.25	0.59
			75A			2.5	0.59
			100A			2.5	0.60
WY3CS-123	125AF	3CT TYPE	120A			2.5	0.60
			150A			2.5	0.66
			50A			1.25	0.66
			60A			1.25	0.66
			75A			2.5	0.66
WY3CS-253	250AF	3CT TYPE	100A	2.5	0.67		
			120A	2.5	0.67		
			150A	5	0.68		
			200A	1.25	0.54		
			250A	1.25	0.55		
			300A	2.5	0.55		
			200A	2.5	0.56		
			250A	2.5	0.57		
			300A	2.5	0.58		

TRANS=NCCT 트랜스포머  
 REACTOR 리액터  
 SSR 무전선블레이  
 TPR 전력조정기  
 SMPSS 스위칭파워  
 NF 노이즈필터  
 HF 하모닉필터  
 SPD 서지보호기  
 RELAY 보호계전기  
 ELD=GFRL 누전경보기  
 ZCT 영상변류기  
 METER 판넬메타  
 CT=VVT 계기용변성기  
 SHUNT=FAAN 션트팬

# 3PHASE INSTALLING TYPE (3상 일체형) CURRENT TRANSFORMER

0.72~1.2kV (50~300A)

## ● Dimension

- WY3CS-052S, WY3CS-053S

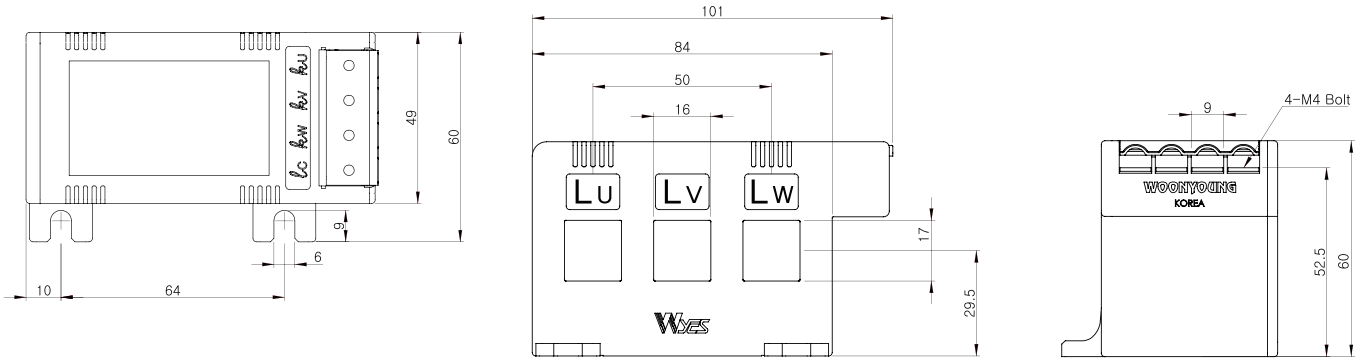

- WY3CS-052, WY3CS-053

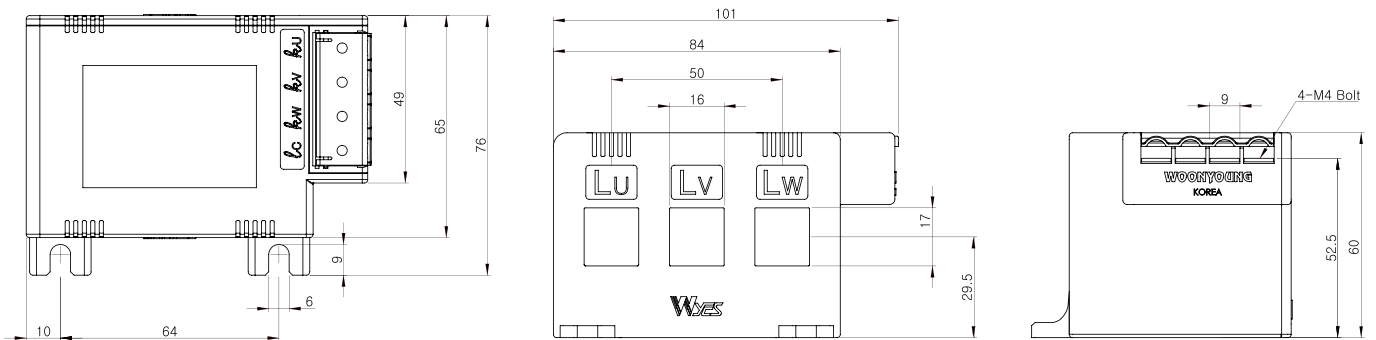

- WY3CS-122, WY3CS-123

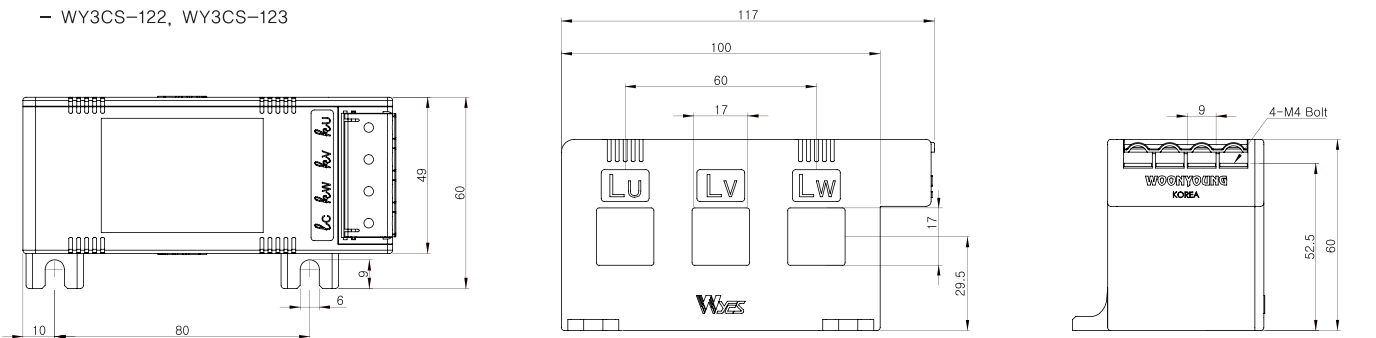

- WY3CS-252, WY3CS-253

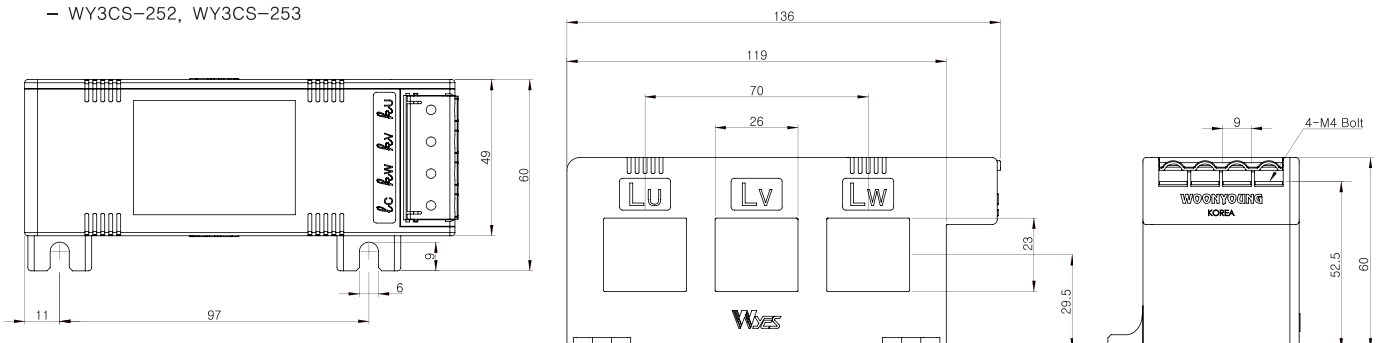

# SPLIT TYPE (분할형) CURRENT TRANSFORMER

0.72kV (50~5000A)



- Standard :KS C 1706, IEC 61869-2, JEC 1201, IEEE C 57.13

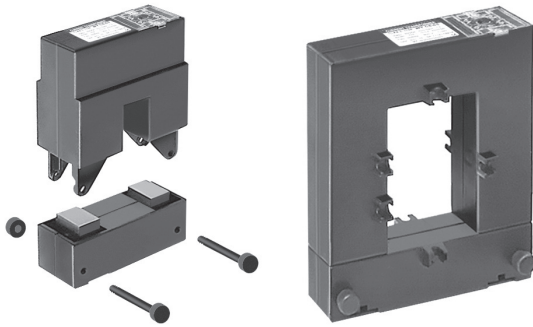

### ● Specifications

- Split Core Type
- Maximum voltage : 0.72kV
- Withstand : 3kV/1min
- Frequency : 50Hz or 60Hz

### ● Features

- Protect cover
- Easy to install panel mounting kit

### ● Illustration & Drawing

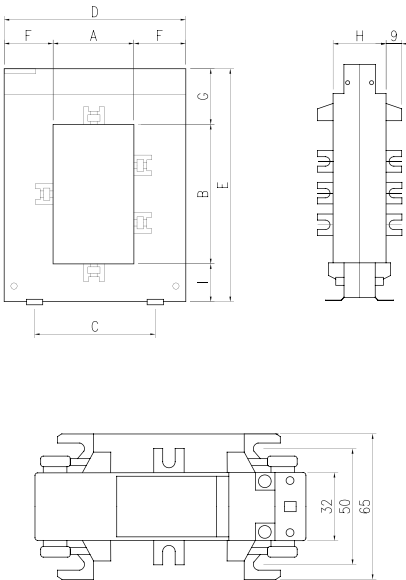

### ● Single Ratio Type

MODEL	Primary (A)	Secondary (A)	Burden(VA)	
			Class 3.0	Class 1.0
WYSC-23	100~120	1, 5	1.25	-
	150~200		1.5	-
	250		2	-
	300		3.75	-
WYSC-58	400	1, 5	5	-
	250		2	-
	300~400		3	-
	500~800		-	5
WYSC-88	1000	1, 5	-	10
	250		-	3.75
	300		-	5
	400		-	10
	500~800		-	15
WYSC-812	1000	1, 5	-	15
	1200~1250		-	15
	500		-	10
	600~800		-	15
WYSC-816	1500	1, 5	-	15
	1000		-	15
	3000~5000		-	15

### ● Connection Diagram

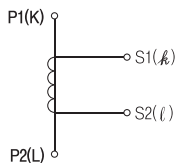

### ● Dimension

unit : (mm)

MODEL	A	B	C	D	E	F	G	H	I	Weight(Kg)
WYSC-23	20	30	51	89	111	34	47	40	32	0.75
WYSC-58	50	80	78	114	145	32	32	32	33	0.9
WYSC-88	80	80	108	144	145	32	32	32	33	1.05
WYSC-812	80	120	108	144	185	32	32	32	33	1.25
WYSC-816	80	160	120	184	245	52	52	52	38	4.3

리액터  
무정전압분류레이  
전력조정기  
스위칭파워  
노이즈 필터  
하모닉 필터  
서지보호기  
보호계전기  
영상변류기  
판넬메타  
계기용변성기  
선트팬

● Type Information

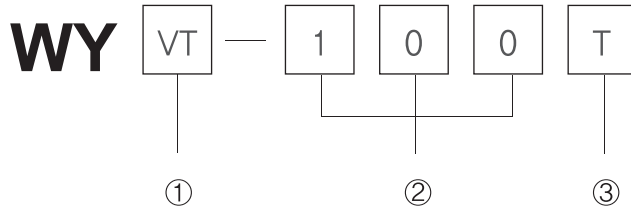

● General Specifications

- Metering or Protection Relay
- Indoor type
- Case : Poly carbonate (PC)

① Kind

VT	Voltage Transformer (1Phase)
EVT	Earthed Voltage Transformer (1Phase)
3VT	Voltage Transformer (3Phase)
3EVT	Earthed Voltage Transformer (3Phase)

② Burden (VA)

50, 100, 200, 500	VT
50, 100, 200, 500	EVT
50(25X2)	3VT
50(16X3)	3EVT

③ Line Part

F	Fuse	
TF	Tertiary & Fuse	
V	Line to Line V.T(3P3W)	3VT
Y	Line to Earth V.T(3P4W)	3EVT

VT, EVT

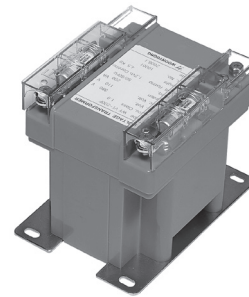

3VT, 3EVT



● Rated Voltage

Item	Primary Voltage(V)	Secondary Voltage(V)	Tertiary Voltage(V)	
VT	WY3VT	110 ~ 600	110	-
EVT	WY3EVT-Y	110/√3 ~ 480/√3	110/√3 or 190/√3	190/3V or 110/3
		the other (by specified)	110/√3 or 190/√3	190/3V or 110/3



# VOLTAGE TRANSFORMER (VT)

0.72~1.15kV (50~500VA)

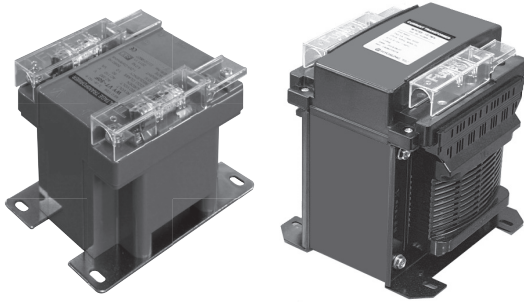

### Specifications

- Maximum voltage : 0.72~1.15kV
- Frequency : 60Hz (standard) 50/60Hz  
(by specified) classification
- Over voltage factor : 1.2Vn (KS C IEC 61869-3)
- Fuse : AC500V (MAX) 10,3×38mm

### Connection Diagram

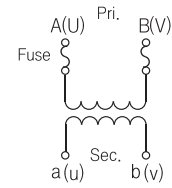

MODEL	Rated Voltage(V)		Class (%)	Rated Burden (VA)	Fuze (A)	Weight (kg)
	1'st	2'nd				
WYVT-50F	110 ~ 600	110 or 220	1.0	50	2A	≒2,5
WYVT-100F				100		≒4,0
WYVT-200F				200		≒5,0
WYVT-300F				300		≒7,1
WYVT-500F				500		≒10,0

※ Type "F" : Fuse in type

### Illustration & Drawing

Type : A

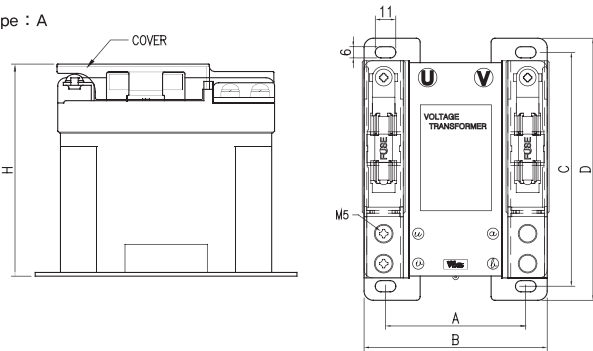

### Dimension

unit : (mm)

MODEL	A	B	C	D	H	Type
WYVT-50F	75	98	125	140	110	A
WYVT-100F	85	108	125	140	110	
WYVT-200F	95	113	125	140	123	B
WYVT-300F	98	140	106	126,5	136,5	
WYVT-500F	114	160	134	156	180	C

Type : B

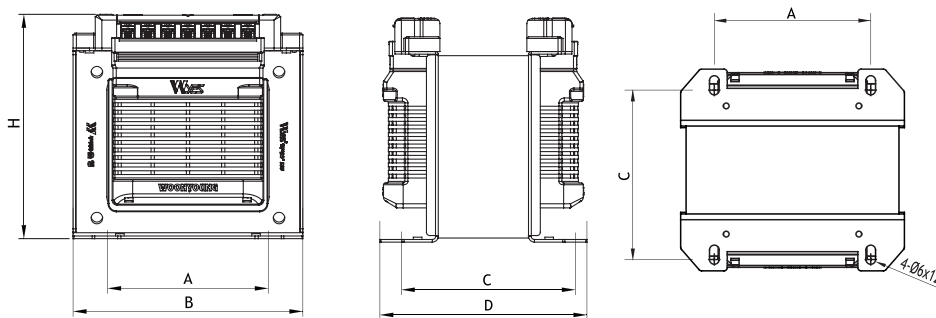

Type : C

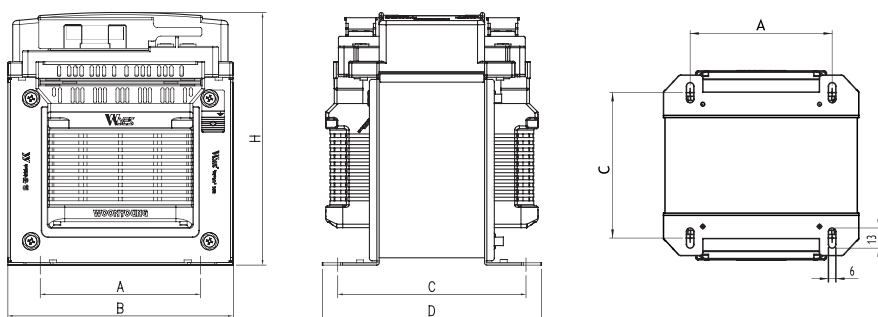

리액터  
무정전압레일  
전력조정기  
스입출파워  
노이즈필터  
하모닉필터  
서지보호기  
보호계전기  
누전경보기  
영상변류기  
판넬메타  
계기용변성기  
선편

# EARTHED TYPE VOLTAGE TRANSFORMER (EVT)

0.72~1.15kV (50~500VA) Over voltage factor : 1.2Vn Cont. / 1.9Vn 30s

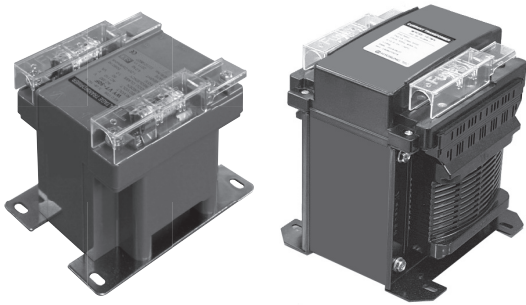

## ● Specifications

- Maximum voltage : 0.72~1.15kV
- Frequency : 60Hz (standard) 50/60Hz  
(by specified) classification
- Over voltage factor : 1.2Vn Cont. / 1.9Vn 30s (KS C IEC 61869-3)

MODEL	RatedVoltage (V)			Class (%) 2'st/3'ry	Rated Burden(VA) 2'nd/3'ry	Fuze (A)	Weight (kg)
	1'st	2'nd	3'ry				
WYEVT-50F	110/√3~ 480/√3	110/√3~ 190/√3	-	1.0	50	2	≒3.0
WYEVT-100F					100		≒4.0
WYEVT-200F					200		≒4.0
WYEVT-500F					500		≒10.0
WYEVT-25TF	110/√3~ 480/√3	110/√3~ 190/√3	110/3 or 190/3	1.0/3.0	25/50	2	≒4.0
WYEVT-50TF					50/100		≒5.0
WYEVT-100TF					100/200		≒6.0
WYEVT-200TF					200/400 or 500		≒10.0

※ Type "F" : Fuse in type

## ● Illustration & Drawing

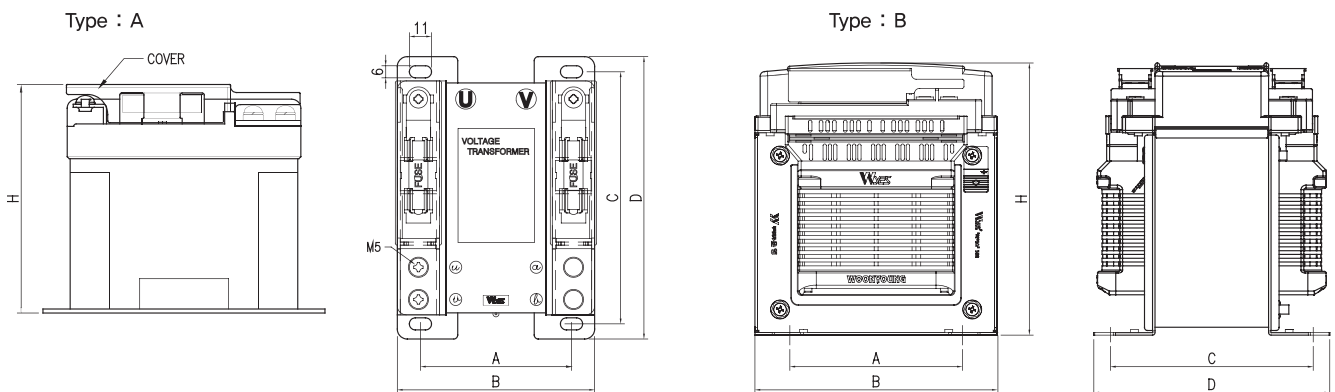

## ● Dimension

unit : (mm)

MODEL	A	B	C	D	H	Type
WYEVT-50F WYEVT-25TF	75	98	125	140	110	A
WYEVT-100F WYEVT-50TF	85	108	125	140	110	
WYEVT-200F WYEVT-100TF	95	113	125	140	123	B
WYEVT-500F WYEVT-200TF	114	160	134	156	180	

## • Connection Diagram

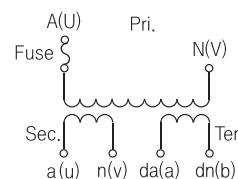

### ⚠ 주의

3차 권선의 Open Terminal 간 부담이 작게 되면 잔류 전압이 발생되어 계전기의 오동작이 될 수 있으므로 사용 부담은 정격 부담이 70~100%가 되도록 하여 주십시오.

### ⚠ Caution :

Please the rated burden have to be from 70 to 100%. If the burden between the Open Terminal and the Open Terminal at the third winding is low, it generates residual voltage.

# EARTHED TYPE VOLTAGE TRANSFORMER (EVT)

0.72~1.15kV (50~400VA) Over voltage factor : 1.2Vn Cont. / 1.9Vn 8h

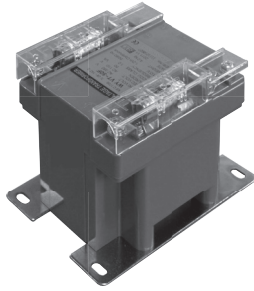

## Specifications

- Maximum voltage : 0.72~1.15kV
- Frequency : 60Hz (standard) 50/60Hz  
(by specified) classification
- Over voltage factor : 1.2Vn Cont. / 1.9Vn 8h (IEC61869-3)
- Fuse : None

Model	RatedVoltage(V)			Class(%) 2 <sup>st</sup> /3 <sup>ry</sup>	Rated Burden(VA) 2 <sup>nd</sup> /3 <sup>ry</sup>	Weight (kg)	Over Voltage Factor
	1 <sup>st</sup>	2 <sup>nd</sup>	3 <sup>ry</sup>				
WYEVT-50	$110 / \sqrt{3} \sim 480 / \sqrt{3}$	$110 / \sqrt{3}$ or $190 / \sqrt{3}$	-	1.0	50	≈4.0	1.2Vn Cont. / 1.9Vn 8h
WYEVT-100							
WYEVT-25T	$110 / \sqrt{3} \sim 480 / \sqrt{3}$	$110 / \sqrt{3}$ or $190 / \sqrt{3}$	$110 / 3$ or $190 / 3$	1.0/3P	25/50	≈5.0	1.2Vn Cont. / 1.9Vn 8h
WYEVT-50T							

## Connection Diagram

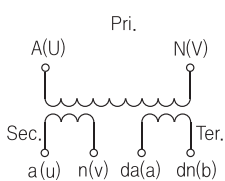

### 주의

3차 권선의 Open Terminal 간 부담이 작게 되면 잔류 전압이 발생되어 계전기의 오동작이 될 수 있으므로 사용 부담은 정격 부담이 70~100%가 되도록 하여 주십시오.

### Caution :

Please the rated burden have to be from 70 to 100%. If the burden between the Open Terminal and the Open Terminal at the third winding is low, it generates residual voltage.

## Illustration & Drawing

Type : A

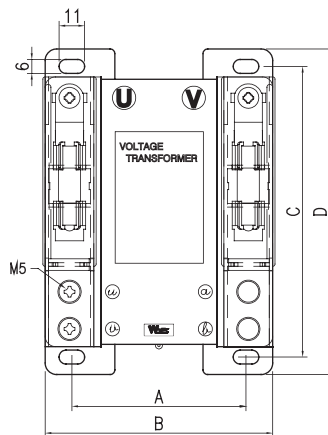
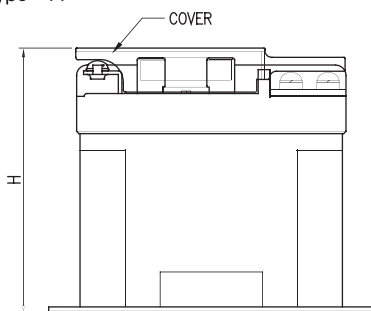

## Dimension

unit : (mm)

Model	A	B	C	D	H	Type
WYEVT-50 WYEVT-25T	85	108	125	140	110	A
WYEVT-100 WYEVT-50T	95	113	125	140	123	

# 3Ø VOLTAGE TRANSFORMER (3Ø VT)

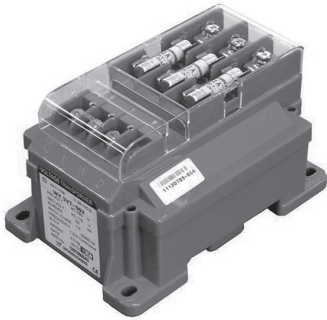

## Specifications

- Maximum voltage : 0.72~1.15kV
- Frequency : 60Hz (Standard) 50/60Hz  
(by specified) classification
- Over voltage factor : 1.2Vn Cont. / 1.9Vn 30s  
(KS C IEC 61869-3)
- Fuse : AC500V, 1A(10,3×38mm)
- Phase : 3Phase

MODEL	Rated Voltage(V)		Class (%)	Rated Burden (VA)	Weight (kg)
	1'st	2'nd			
WY3VT-50V	110 ~ 600	110 ~ 220	1.0	25×2(50)	≒4.0
WY3EVT-50Y	380/√3	190/√3 ~ 110/√3		16×3(50)	≒4.5

### 경고

지락사고시 건전상에서는 √3배 전압이 유기되어 본제품이 손상될 우려가 있으니 차단보호 장치가 없는 경우는 1차측 N 접지 단자를 사용 하지 마십시오.

### Caution :

It don't use the N earth terminal at primary if don't have the shutoff protection equipment. When ground accident , this product may be broken because it conducts times of voltage.

## Connection

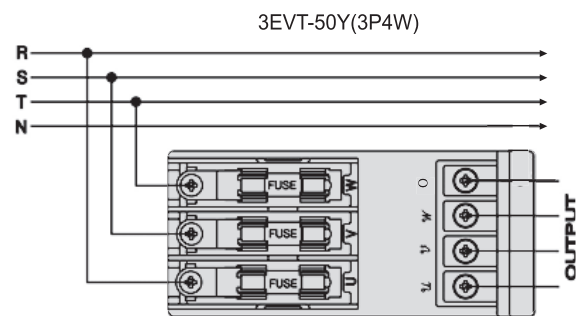
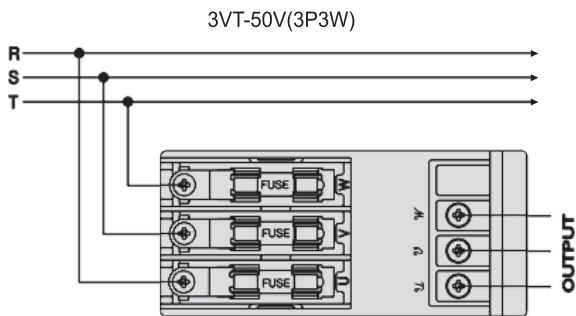

## Connection Diagram

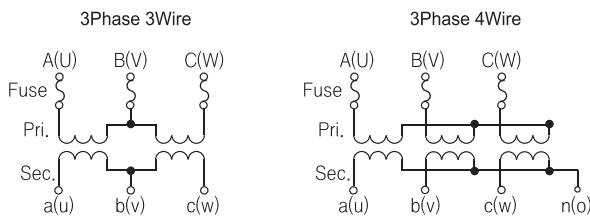

### 경고

- ※ 1차 N(접지)단자는 중선선에 연결하지 마십시오.
- ※ 본제품은 접지 보호장치가 없는 선로에서 접지사고 발생시 제품이 손상될 수 있습니다. 접지보호 장치가 없을시 단상GPT를 조합하여 사용하는것이 효과적입니다.

### Caution:

- ※ N(ground) terminal disconnects a neutral line.
- ※ When ground accident, this product may be broken at line without ground protection equipment. When it don't have ground protection equipment, it is effective to use a combination of it and a single-phase GPT.

## Illustration & Drawing

