

NOISE FILTER

30 500V 보급형 General Type



● Features

- 2 Mounting Option
 - WYF****D : Din Rail Mounting
 - WYF**** : Screw Mounting
- Wide Band : High Attenuation
- Band Width : 150KHz ~ 30MHz
- Low Leakage
- RoHS Compliant
- KC(안전인증) Approved by HK03001 – 19008A (Without "C" Type)
- Inverter Output Type : Model Type"C" (WYFTH05T1C)

● Specifications

ITEM	MODEL	SYMBOL	WYFTH05T1A (D)	WYFTH10T1A (D)	WYFTH15T1A (D)	WYFTH20T1A (D)	WYFTH30T1A (D)
			WYFTH05T1C (D)	WYFTH10T1C (D)	WYFTH15T1C (D)	WYFTH20T1C (D)	WYFTH30T1C (D)
Rated Voltage	V		500				
Rated Current	A		5	10	15	20	30
Frequency	Hz		50 / 60				
Dielectric Withstand	V		2500VAC for 1 minute (Line – Case)				
Insulation Resistance	MΩ		DC 100MΩ at the 500Vdc				
Leakage Current	mA		≤4.0				
Operating Temperature	°C		-25°C ~ +100°C [Refer to Derating Curve TYPE – 2]				
Operating Humidity	RH		35 ~ 85%RH				
Weight	kg		0.5				

※ Derating Curve of page 519

● Circuit Diagram

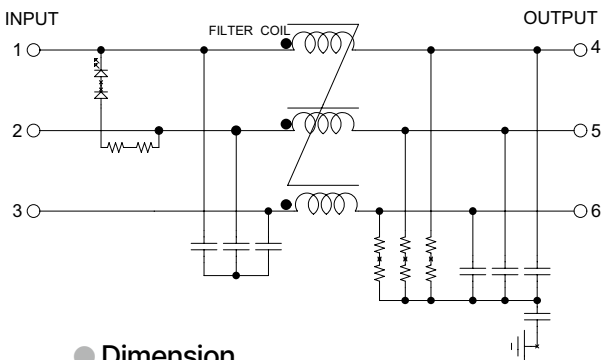

● Terminal

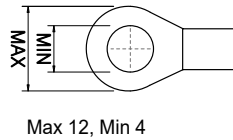

● Characteristics

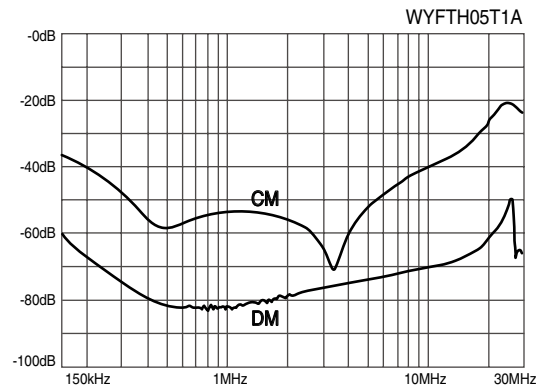

● Dimension

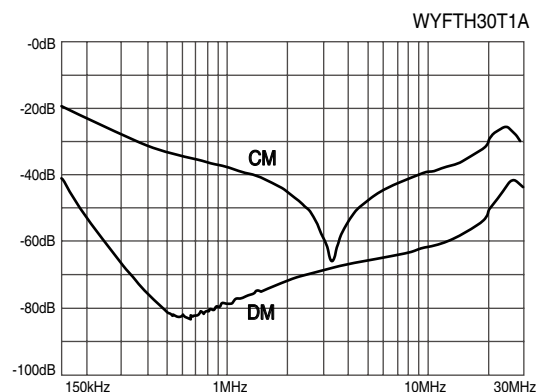
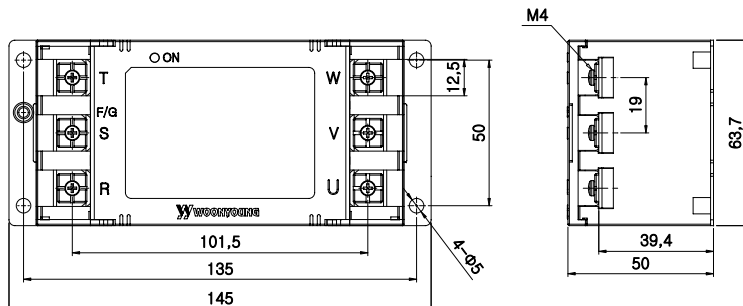

● Characteristics

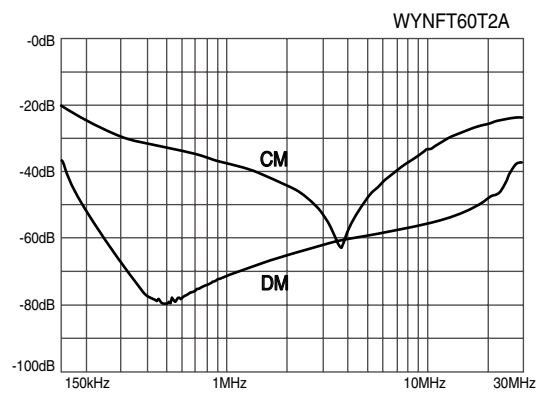
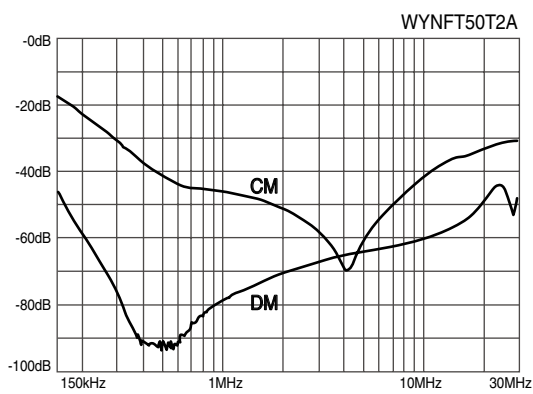
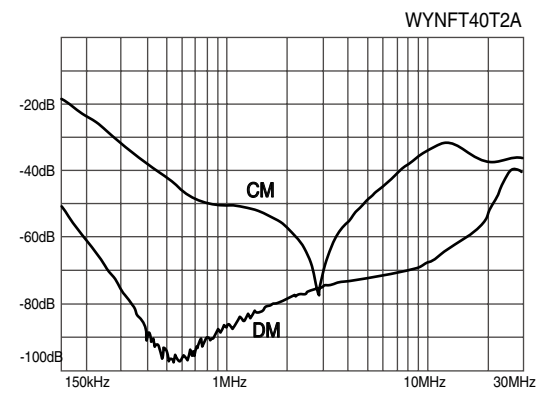
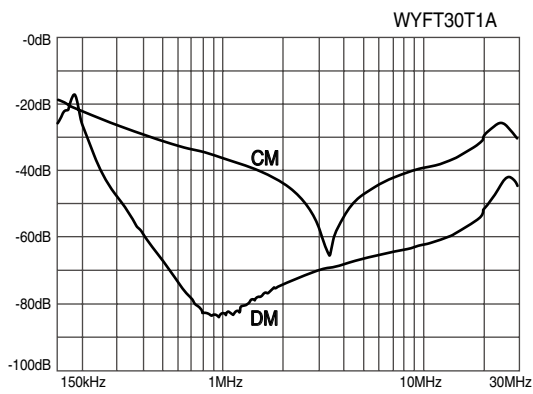
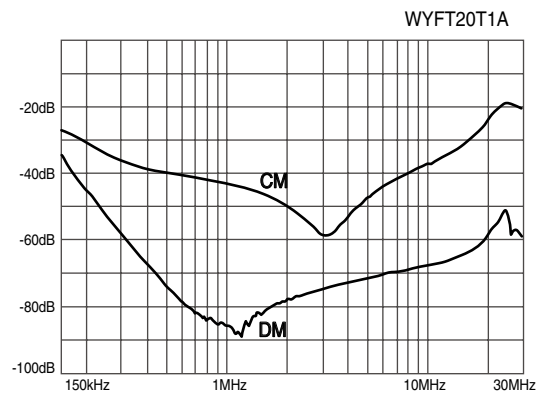
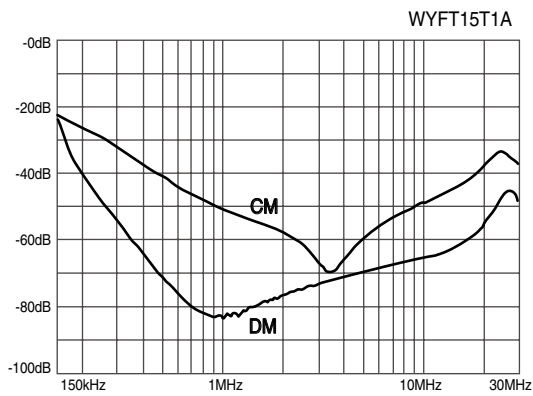
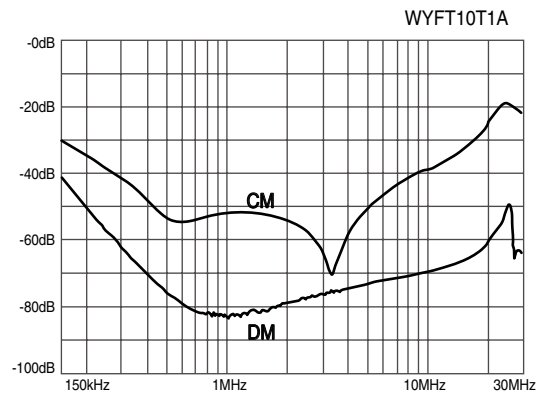
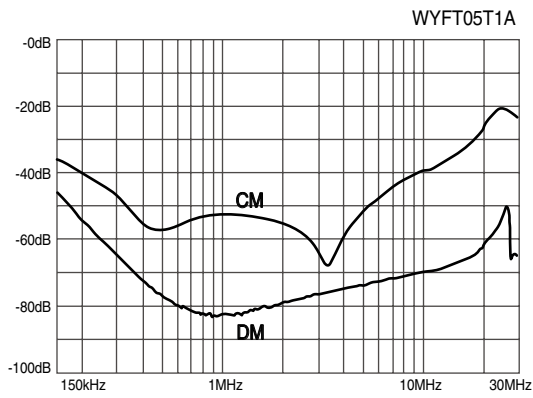

※ CM : Common mode, DM : Differential mode

● Characteristics

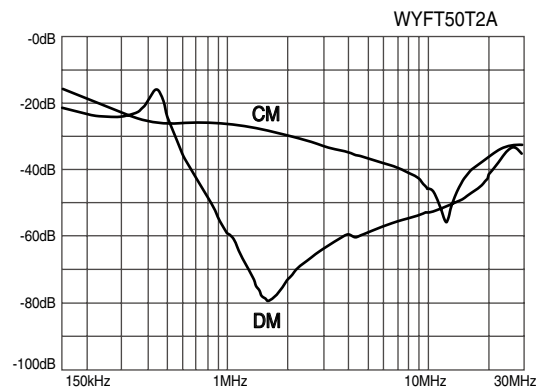
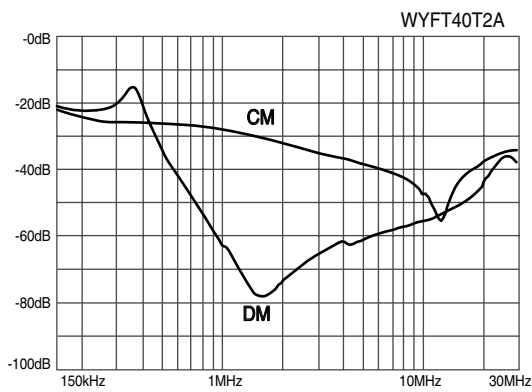
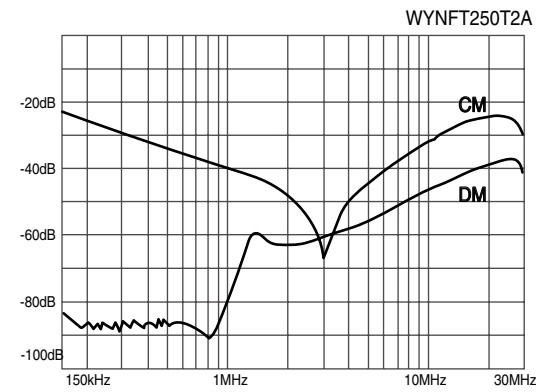
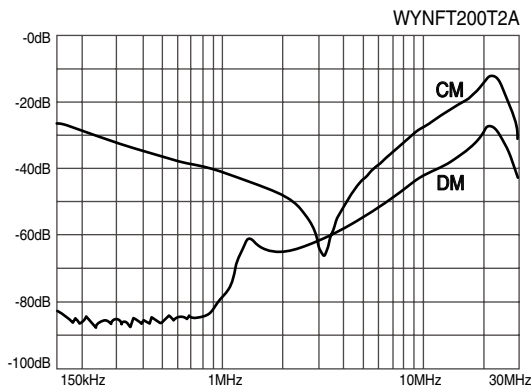
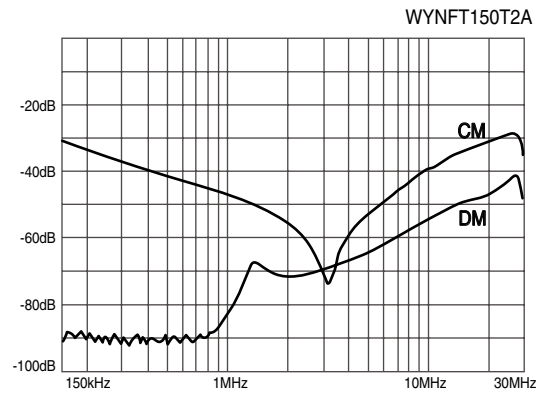
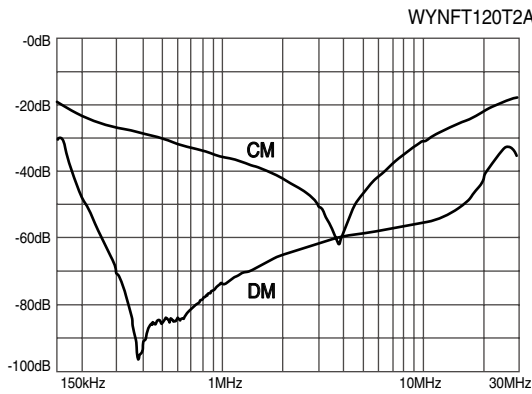
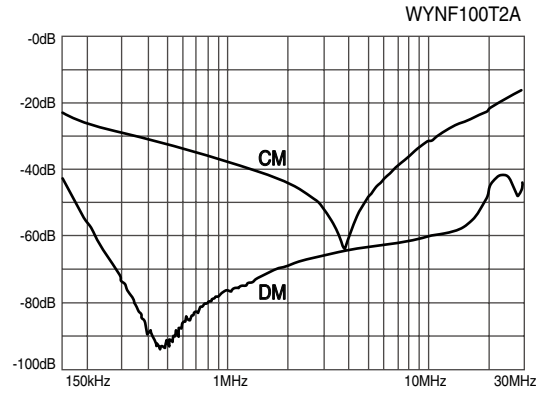
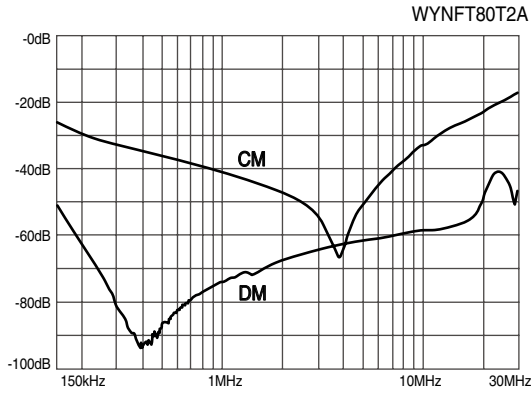

※ CM : Common mode, DM : Differential mode

트랜스포머
REACTOR
리액터
무정전압블레이
SSR
전력조정기
TPR
스위칭파워
SMP
S
노이즈 필터
N/F
하모닉 필터
H/F
서지보호기
SPD
보호계전기
RELAY
누전경보기
ELD=GF
R
영상변류기
ZCT
판넬메타
METER
계기용변성기
CT=VT
SHUNT=FAN
선트팬

● Characteristics

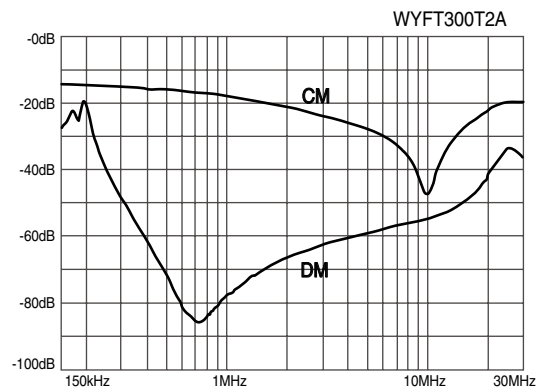
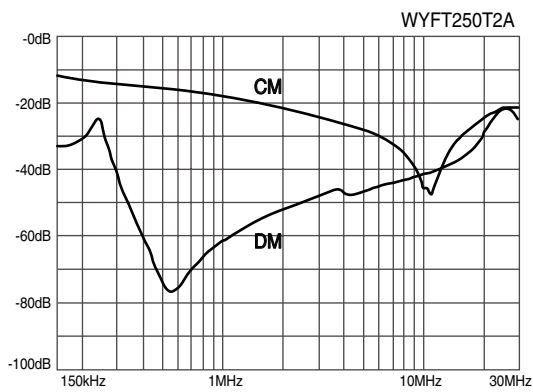
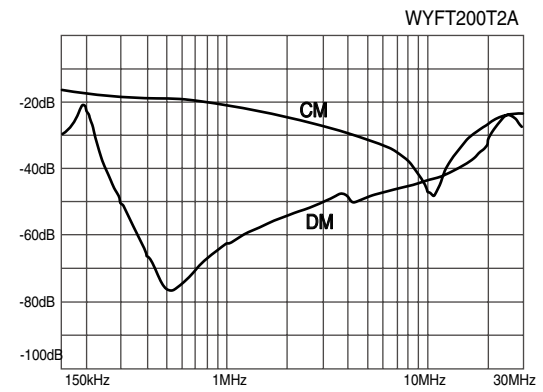
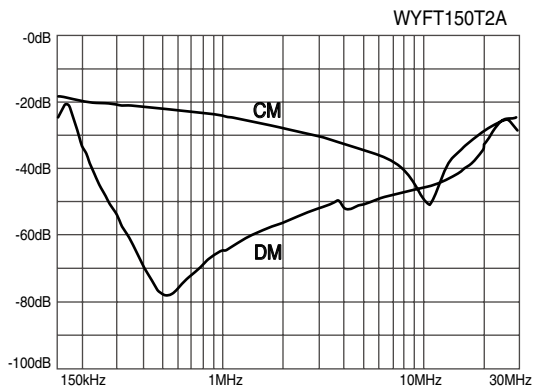
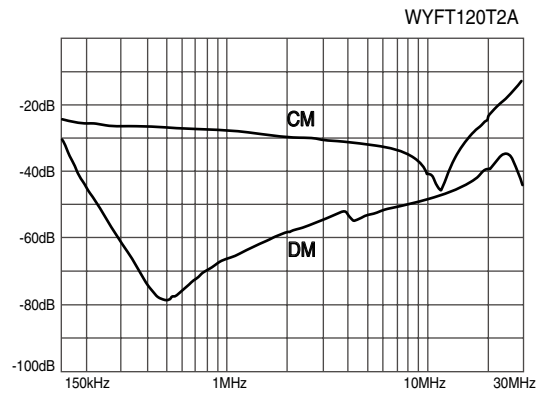
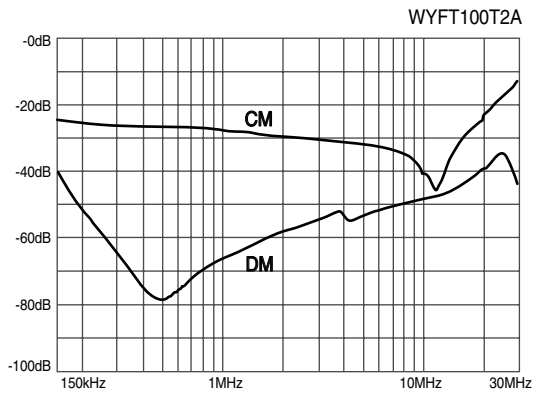
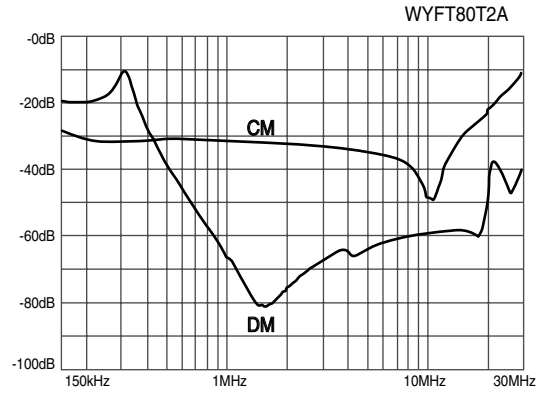
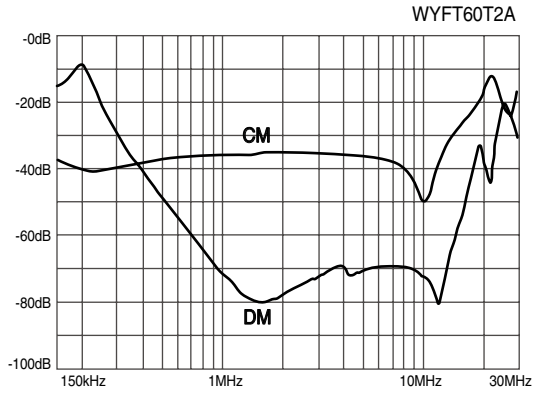

※ CM : Common mode, DM : Differential mode

● Characteristics

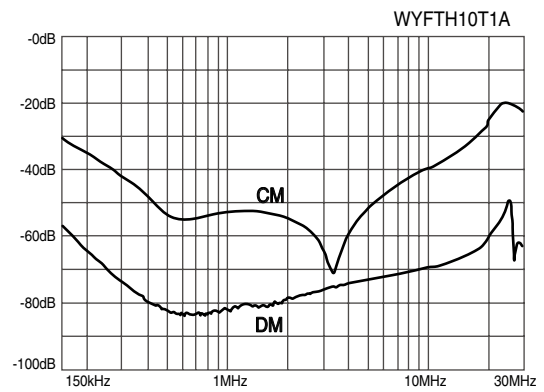
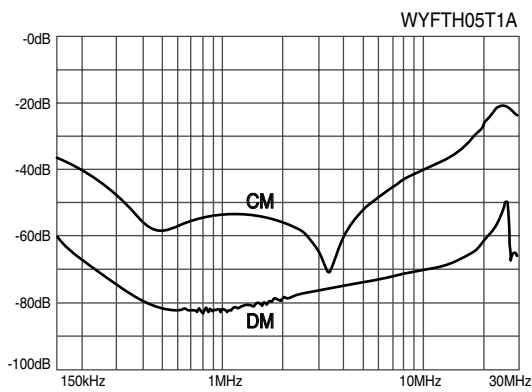
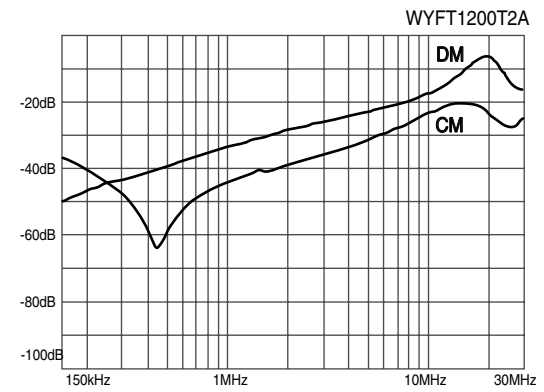
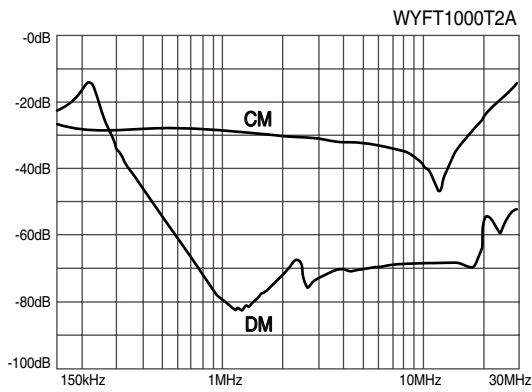
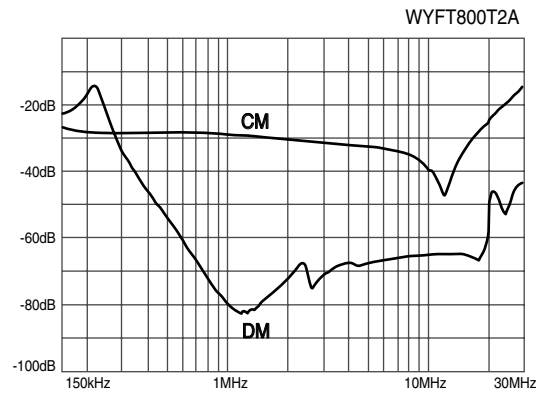
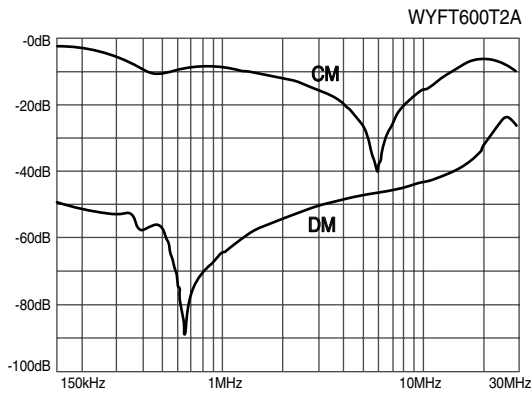
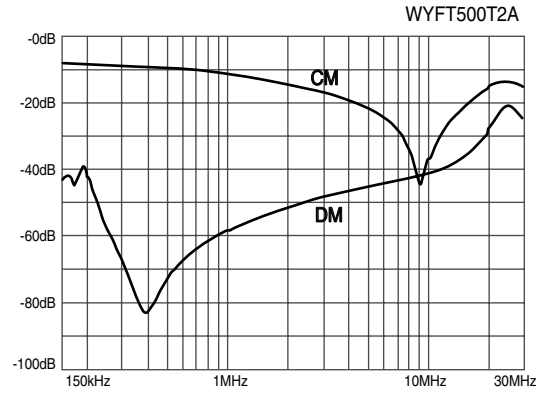
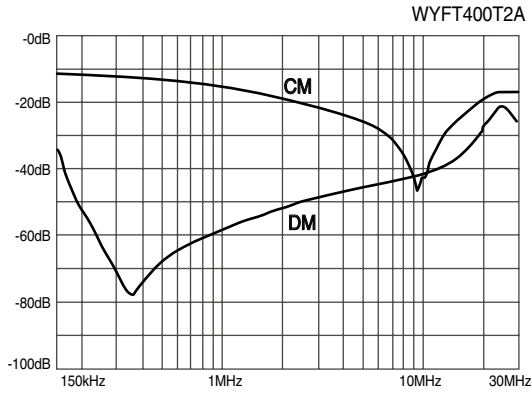

※ CM : Common mode, DM : Differential mode

트랜스포머
REACTOR
리액터
무정전압 레일
SSR
전력조정기
TPR
스위칭파워
SMP
노이즈 필터
H/F
하모닉 필터
서지보호기
SPD
보호계전기
RELAY
누전경보기
ELD=GF
영상변류기
ZCT
판넬메타
METER
계기용변성기
CT=VT
SHUNT=FA
선트팬

NOISE FILTER

30 250V Characteristics

● Characteristics

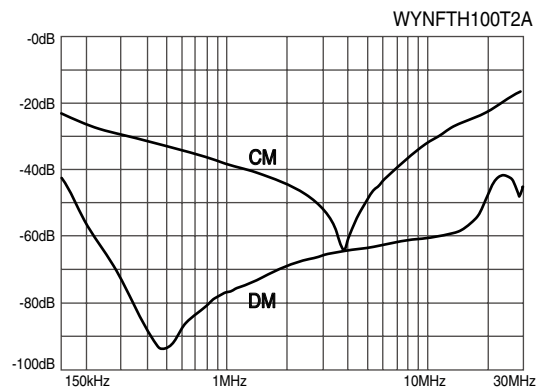
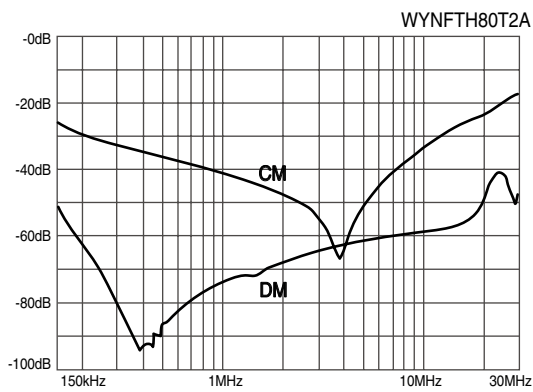
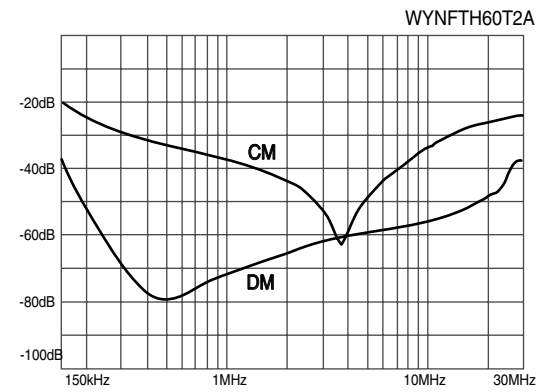
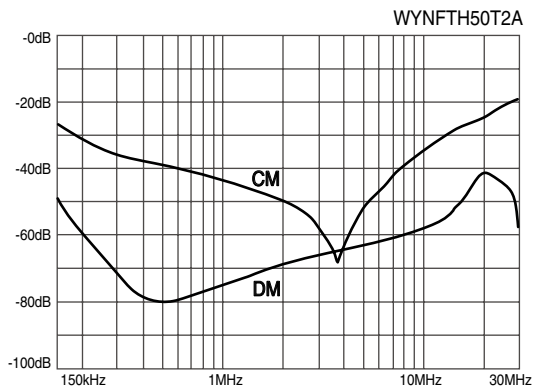
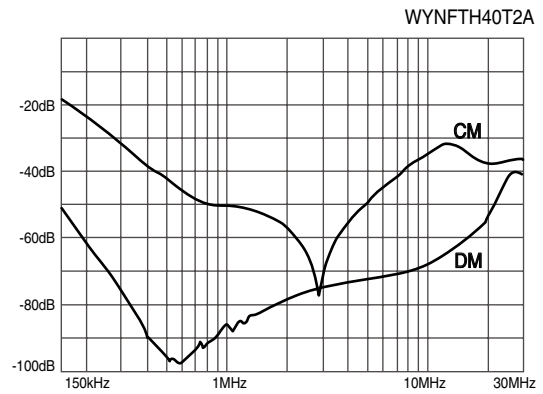
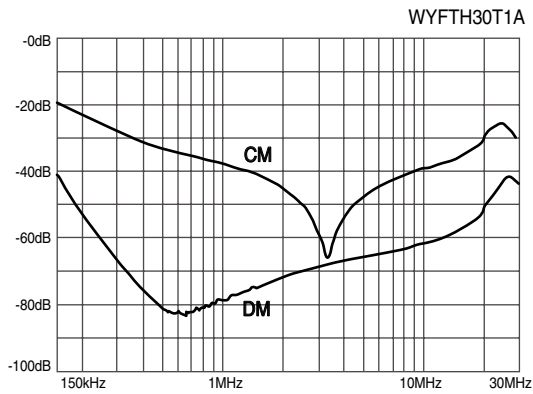
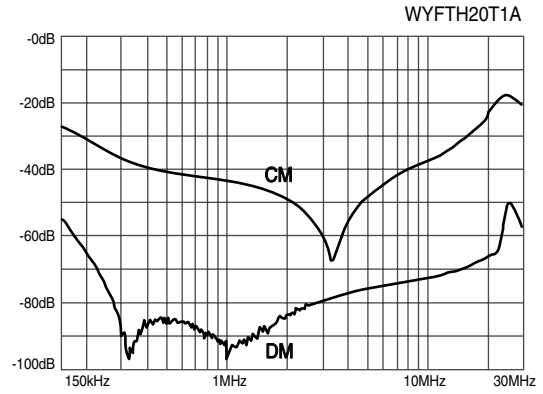
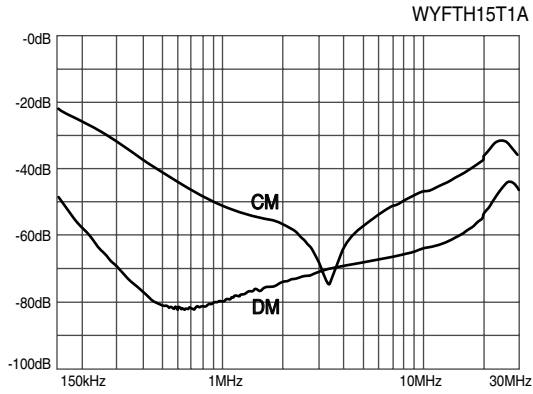

※ CM : Common mode, DM : Differential mode

● Characteristics

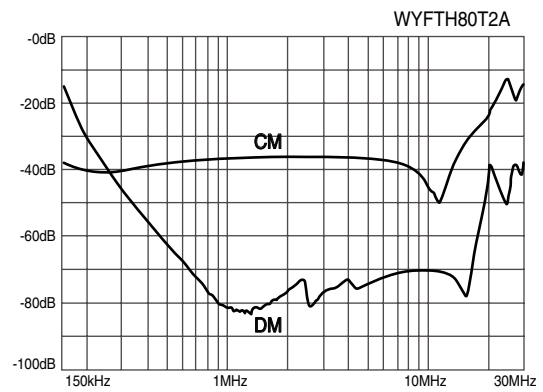
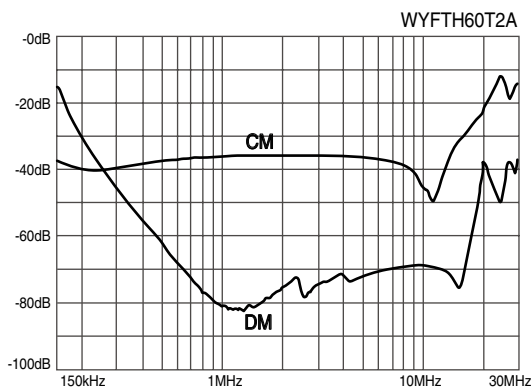
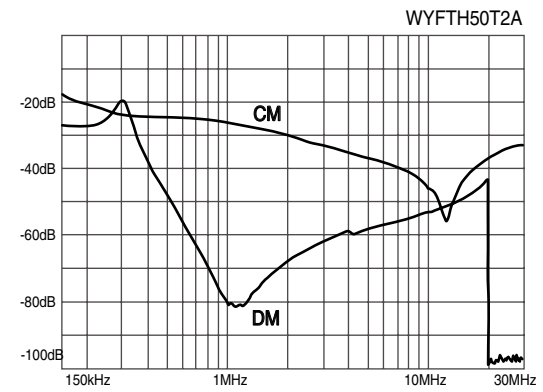
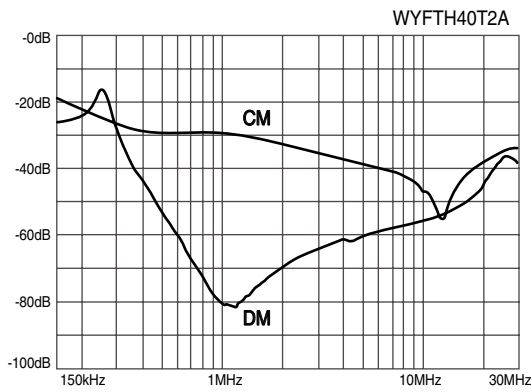
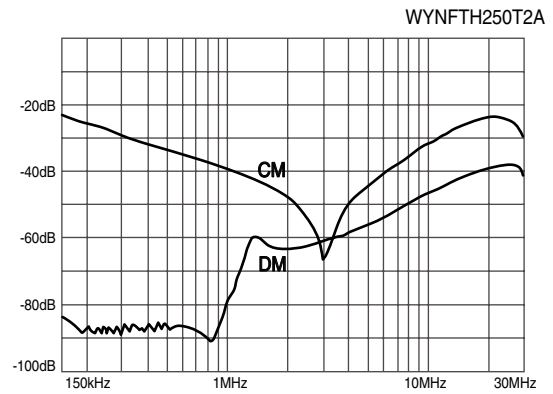
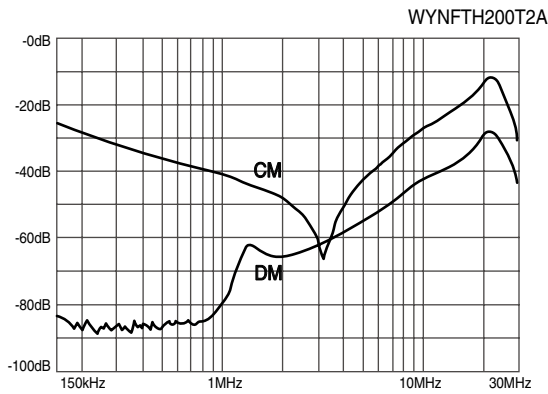
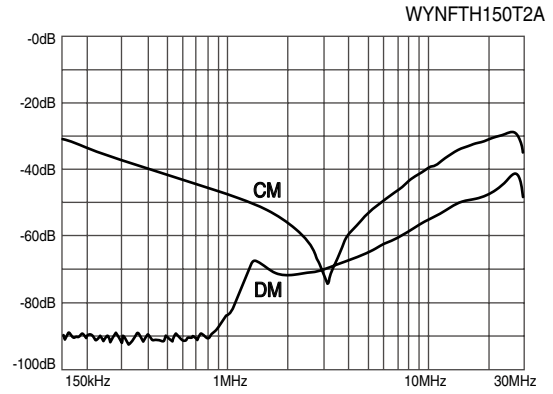
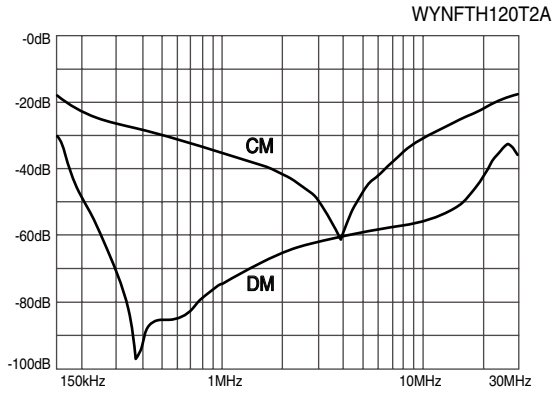

※ CM : Common mode, DM : Differential mode

트랜스포머
REACTOR
리액터
무정전압블레이
SSR
전력조정기
TPR
스위칭파워
SMP
노이즈 필터
N/F
하모닉 필터
H/F
서지보호기
SPD
보호계전기
RELAY
누전경보기
ELD=GF
R
영상변류기
ZCT
판넬메타
METER
계기용변성기
CT=VT
SHUNT=FA
N

● Characteristics

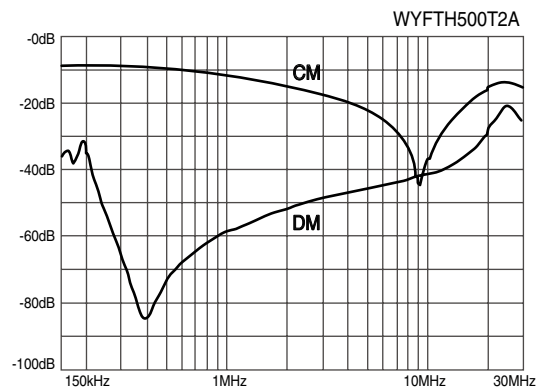
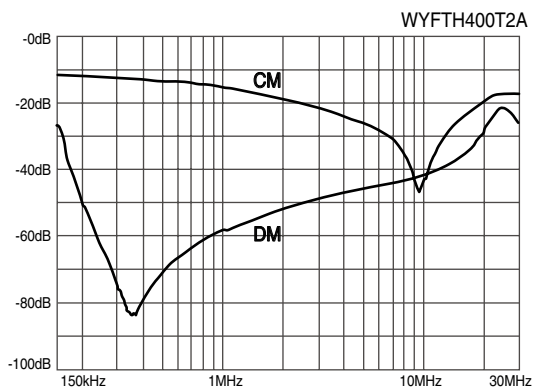
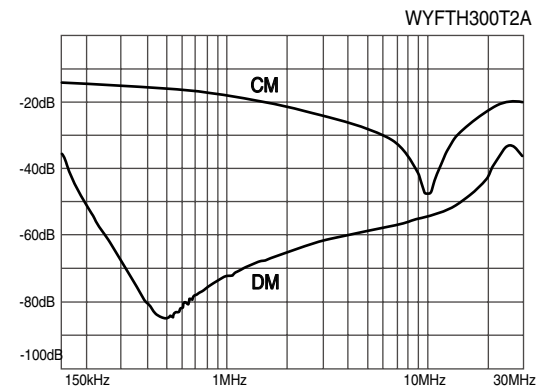
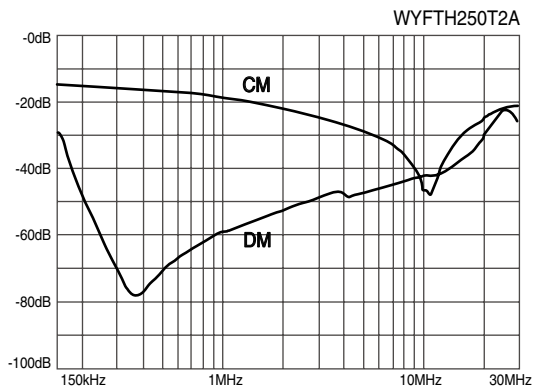
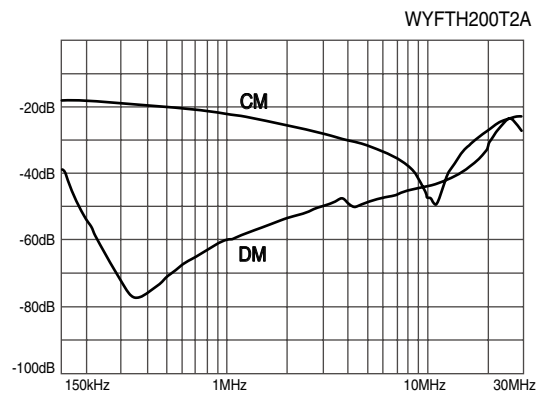
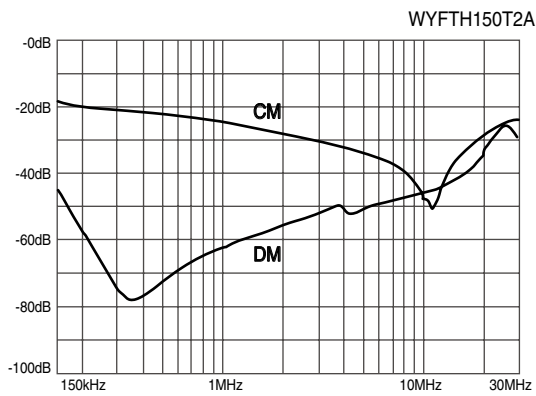
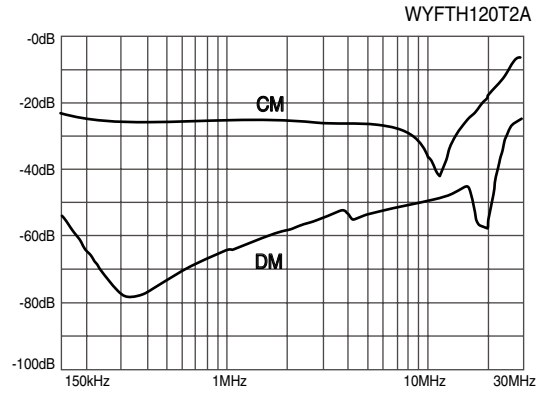
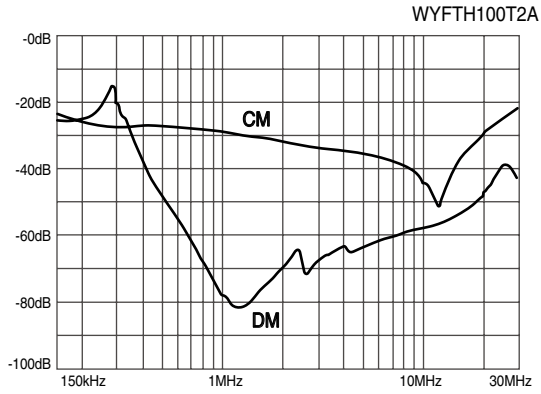

※ CM : Common mode, DM : Differential mode

● Characteristics

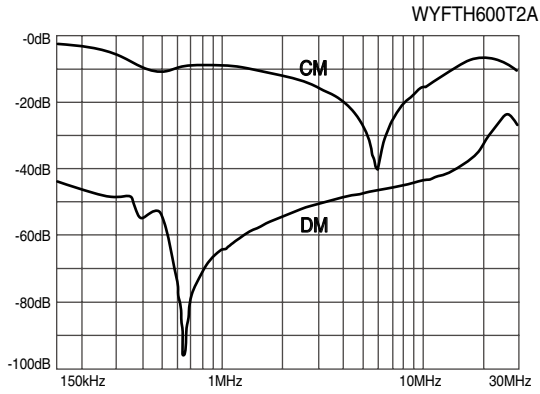

DM

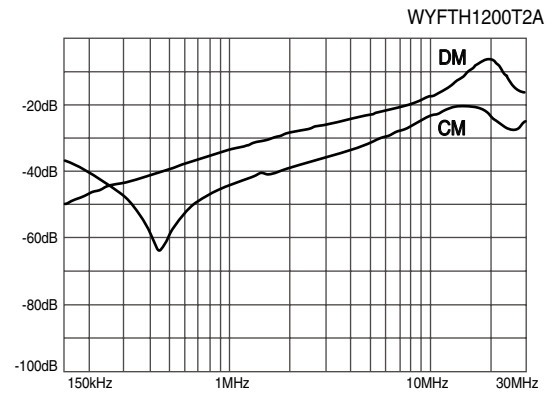
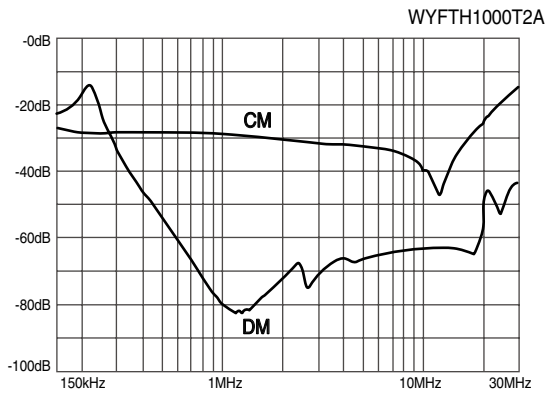
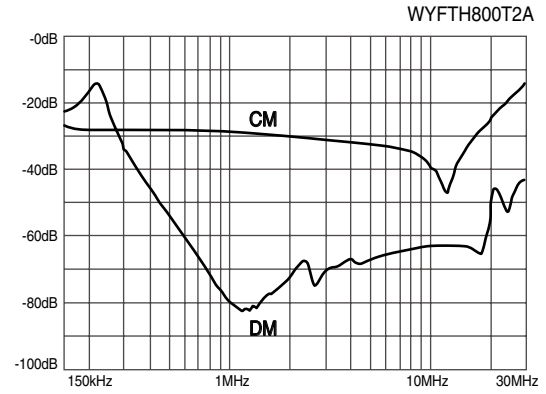

※ CM : Common mode, DM : Differential mode

트랜스포머
REACTOR
리액터
무정전압 레일
SSR
전력조정기
TPR
스위칭파워
SMP
S
노이즈 필터
N/F
하모닉 필터
H/F
서지보호기
SPD
R
보호계전기
RELAY
E
누전경보기
LD=GF
R
영상변류기
ZCT
M
판넬메타
METER
계기용변성기
CT=VT
S
선트랜
SHUNT=FA
N