

노이즈필터

Noise Filter

1Ø 고감쇄형(Multi-Stage Type)

• 1Ø 250V 6~150A

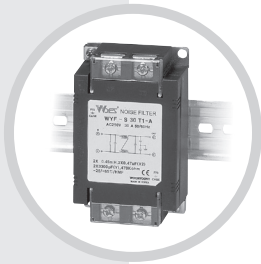



● Features

- 2 Mounting Option
 - WYF****D : Din Rail Mounting
 - WYF**** : Screw Mounting
- Wide Band : High Attenuation
- Band Width : 150KHz~30MHz
- Low Leakage
- RoHS Compliant
- KC(HK03001-18007A)

● Specifications

ITEM	MODEL	SYMBOL	WYFS06T1M (D)	WYFS10T1M (D)	WYFS15T1M (D)	WYFS20T1M (D)	WYFS30T1M (D)
Rated Voltage	V		250				
Rated Current	A		6	10	15	20	30
Frequency	Hz		50/60				
Dielectric Withstand	V		2000Vac for 1 minute or 1075Vdc for 1 minute				
Insulation Resistance	MΩ		500				
Leakage Current	mA		1.8				
Operating Temperature	°C		-25°C ~ +100°C [Refer to Derating Curve TYPE-1]				
Operating Humidity	RH		35~85%RH				
Weight	kg		0.2				

※ "D" : DIN-Rail type of page 184 / Derating Curve of page 103

● Circuit Diagram

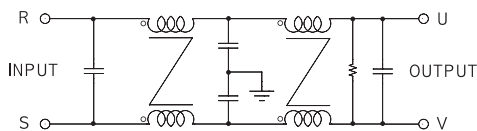

● Terminal

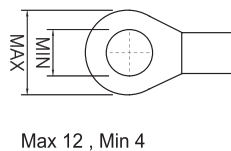

● Characteristics

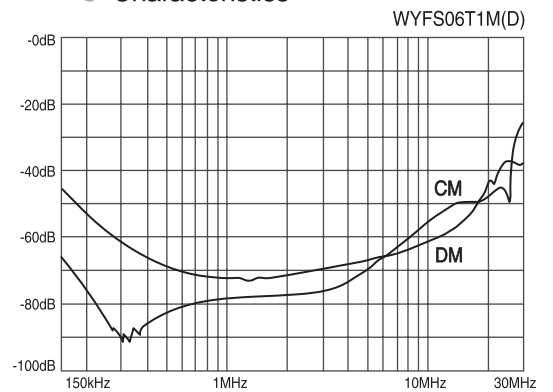

● Dimension

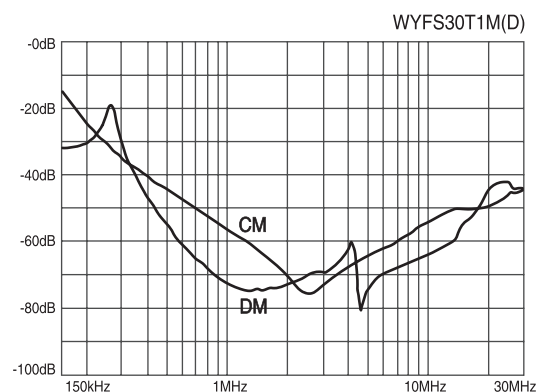
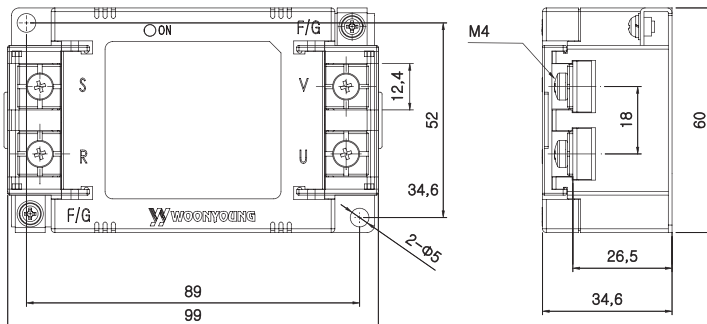

NOISE FILTER

N Series 1Ø 250V 고감쇄형 Multi-Stage Type



● Features

- Wide Band : High Attenuation
- Band Width : 150KHz~30MHz
- RoHS Compliant

● Specifications

ITEM	MODEL	SYMBOL	WYNF S06T2M	WYNF S10T2M	WYNF S15T2M	WYNF S20T2M	WYNF S30T2M	WYNF S40T2M	WYNF S50T2M
Rated Voltage	V		250Vac						
Rated Current	A		6A	10A	15A	20A	30A	40A	50A
Frequency	Hz		50/60						
Dielectric Withstand	V		2000Vac for 1 minute or 1075Vdc for 1 minute						
Insulation Resistance	MΩ		DC 100MΩ at the 500Vdc						
Leakage Current	mA		≤9mA at the 250Vac						
Operating Temperature	°C		-25°C ~ +100°C [Refer to Derating Curve TYPE-1]						
Operating Humidity	RH		35~85%RH						
Weight	kg		2.4						

※ Derating Curve of page 103

● Circuit Diagram

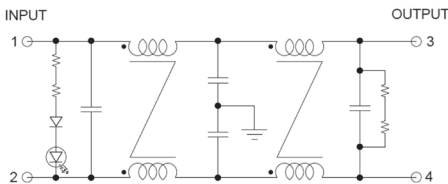

● Terminal

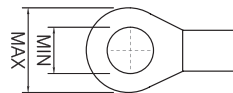

Max 10, Min 4 (6~20A)
Max 16, Min 5 (30~50A)

● Dimension

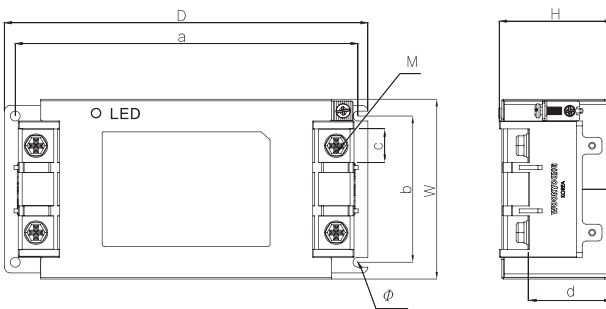

MODEL	W	H	D	a	b	c	d	M	Ø
WYNFS06~20T2M	70.5	45	202	194	51.5	10.5	33	4	5
WYNFS30~50T2M	79.2	48.3	242	232	60	13	33.5	5	5

● Characteristics

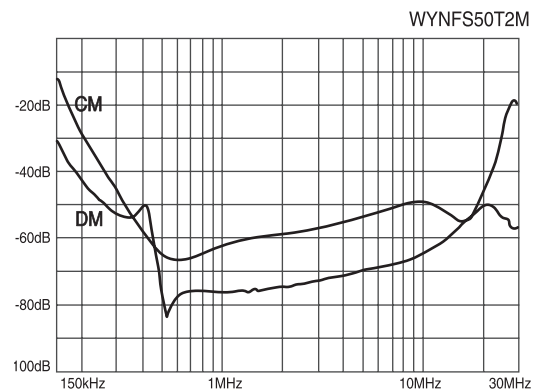
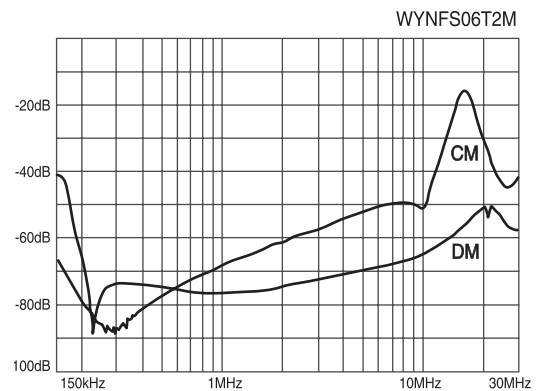

트랜스포머
REACTOR
리액터
무정전압릴레이
SSR
전력조정기
TPR
스위칭파워
SMP
노이즈필터
N/F
하모닉필터
H/F
서지보호기
SPD
보호계전기
RELAY
누전경보기
ELD=GF
R
영상변류기
ZCT
판넬메타
METER
계기용변성기
CT=VT
SHUNT=FA
선트팬

NOISE FILTER

N Series 1Ø 250V 고감쇄형 Multi-Stage Type



● Features

- Wide Band : High Attenuation
- Band Width : 150kHz~30MHz
- RoHS Compliant

● Specifications

ITEM	MODEL	SYMBOL	WYNFS60T2M	WYNFS80T2M	WYNFS100T2M	WYNFS120T2M	WYNFS150T2M
Rated Voltage	V		250Vac				
Rated Current	A		60A	80A	100A	120A	150A
Frequency	Hz		50/60				
Dielectric Withstand	V		2000Vac for 1 minute or 1075Vdc for 1 minute				
Insulation Resistance	MΩ		DC 100MΩ at the 500Vdc				
Leakage Current	mA		≤9mA at the 250Vac				
Operating Temperature	°C		-25°C ~ +100°C [Refer to Derating Curve TYPE-1]				
Operating Humidity	RH		35~85%RH				
Weight	kg		4.5		5.2		

※ Derating Curve of page 103

● Circuit Diagram

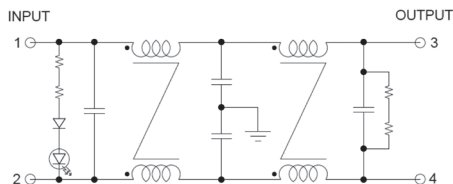

● Terminal

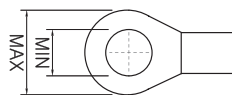
 Max 16, Min 6 (60~80A)
 Max 23, Min 8 (100~150A)

● Characteristics

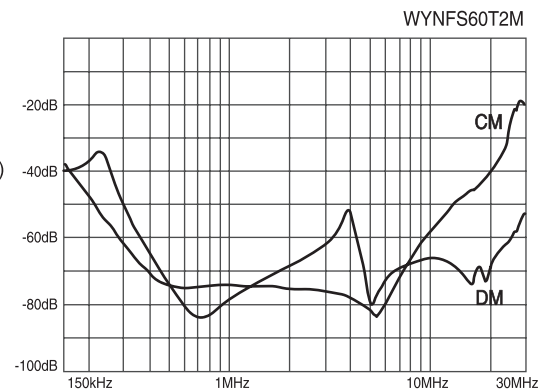

● Dimension

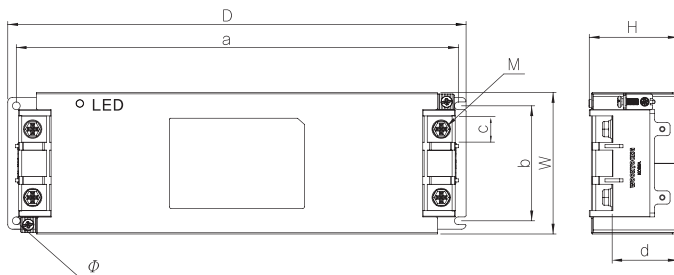

MODEL	W	H	D	a	b	c	d	M	Ø
WYNFS60~80T2M	91	57.2	295	284.5	74	17	42.3	6	5
WYNFS100~150T2M	115	75	384.7	368	96	24	58	8	5

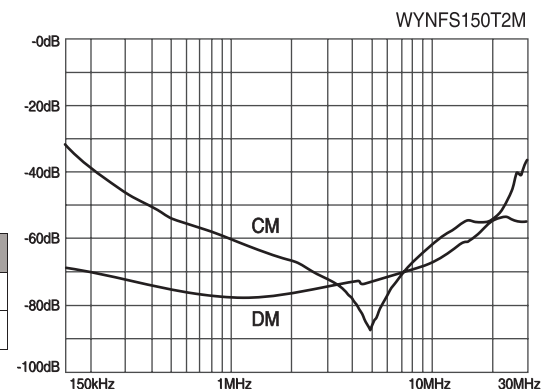

NOISE FILTER

1Ø 250V 고감쇄형 Multi-Stage Type



● Features

- High Attenuation
- High Voltage Pulse Noise
- 2 Stage Filter
- Band Width : 150KHz~30MHz
- RoHS Compliant

● Specifications

ITEM	MODEL	SYMBOL	WYFS06T2M	WYFS10T2M	WYFS15T2M	WYFS20T2M	WYFS30T2M	WYFS40T2M	WYFS50T2M
Rated Voltage	V		250						
Rated Current	A		6	10	15	20	30	40	50
Frequency	Hz		50/60						
Dielectric Withstand	V		2000Vac for 1 minute or 1075Vdc for 1 minute						
Insulation Resistance	MΩ		500						
Leakage Current	mA		9						
Operating Temperature	°C		-25°C ~ +100°C [Refer to Derating Curve TYPE-1]						
Operating Humidity	RH		35~85%RH						
Weight	kg		0.8			1.7			

※ Derating Curve of page 103

● Circuit Diagram

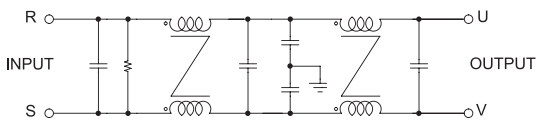

● Terminal

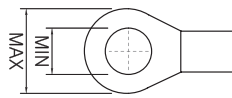

Max 10, Min 4 (6~20A)
Max 14, Min 4 (30~50A)

● Dimension

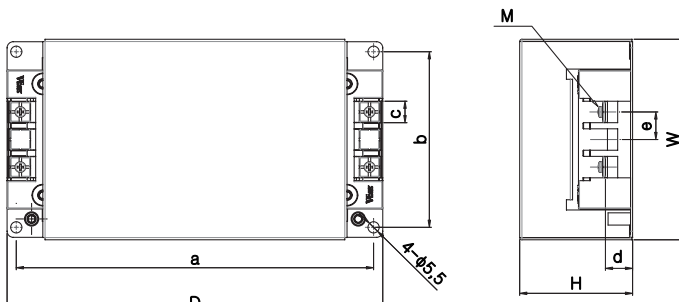

MODEL	W	H	D	a	b	c	d	e
WYFS06~20T2M	98	55	184	175	86	10.5	13	13.5
WYFS30~50T2M	116	75	234	219	98	15	18	27.5

● Characteristics

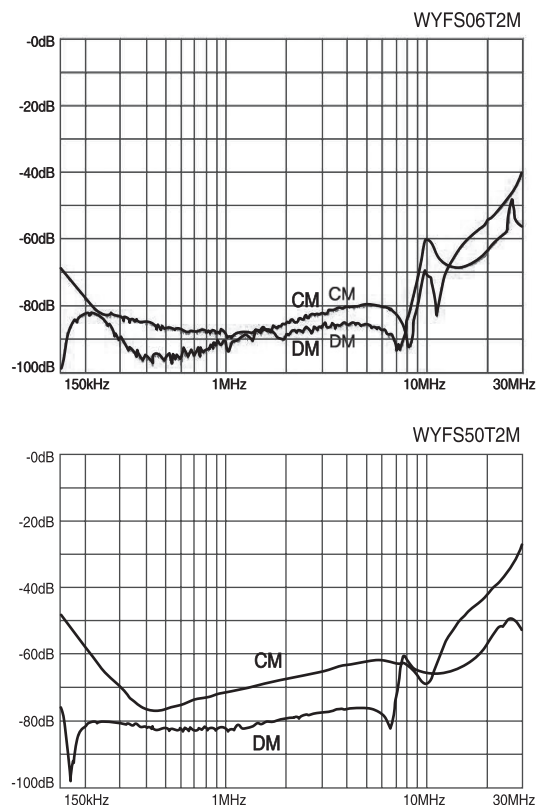

TRANS = NCT 트랜스포머
 REACTOR 리액터
 SSR 무정전압레일
 TPR 전력조정기
 SMPSS 스위칭공파워
 N/F 노이즈 필터
 H/F 하모닉 필터
 SPD 서지보호기
 RELAY 보호계전기
 ELD = GFR 누전경보기
 ZCT 영상변류기
 METER 판넬메타
 CT = VT 계기용 변성기
 SHUNT = FAN 선풍팬

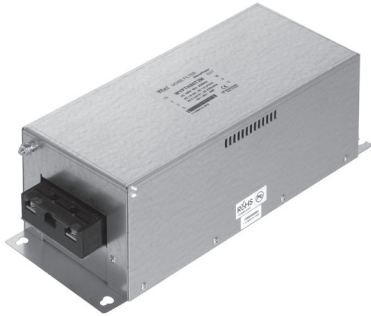

● Features

- High Attenuation
- High Voltage Pulse Noise
- 2 Stage Filter
- Band Width : 150KHz~30MHz
- RoHS Compliant

● Specifications

ITEM	MODEL	SYMBOL	WYFS60T2M	WYFS80T2M	WYFS100T2M
Rated Voltage	V		250		
Rated Current	A		60	80	100
Frequency	Hz		50/60		
Dielectric Withstand	V		2000Vac for 1 minute or 1075Vdc for 1 minute		
Insulation Resistance	MΩ		500		
Leakage Current	mA		9		
Operating Temperature	°C		-25°C ~ +100°C [Refer to Derating Curve TYPE-1]		
Operating Humidity	RH		35~85%RH		
Weight	kg		2,8		

※ Derating Curve of page 103

● Circuit Diagram

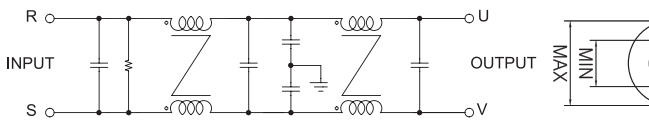

● Terminal

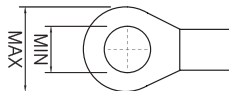

Max 14 , Min 6

● Characteristics

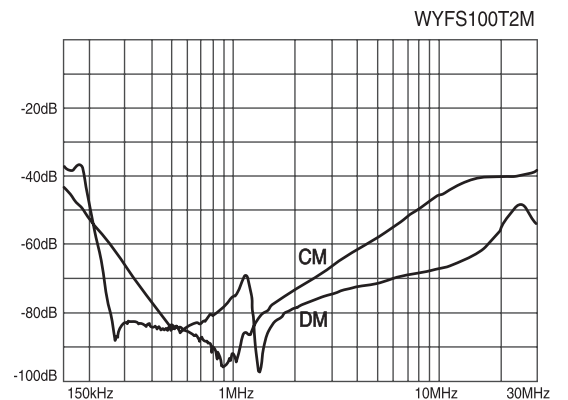
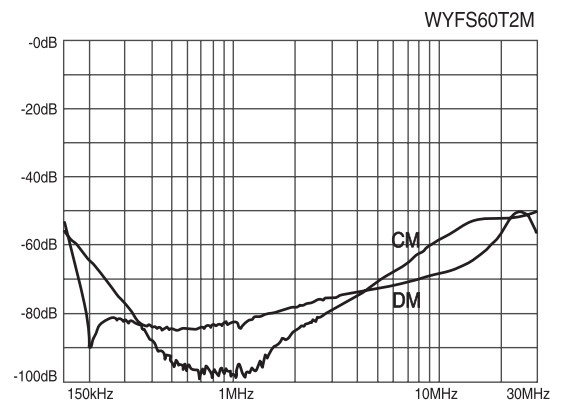

● Dimension

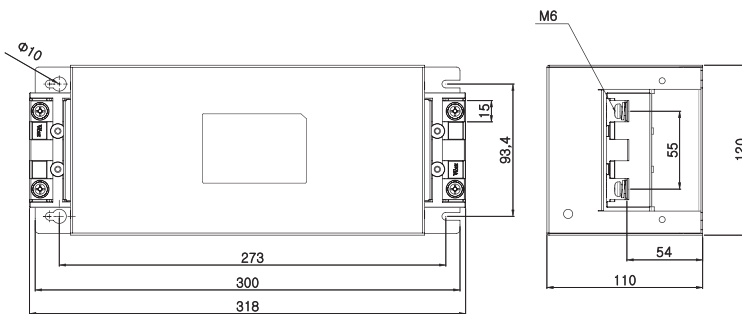

● Characteristics

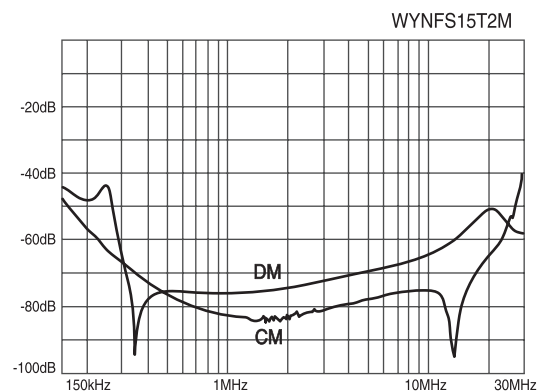
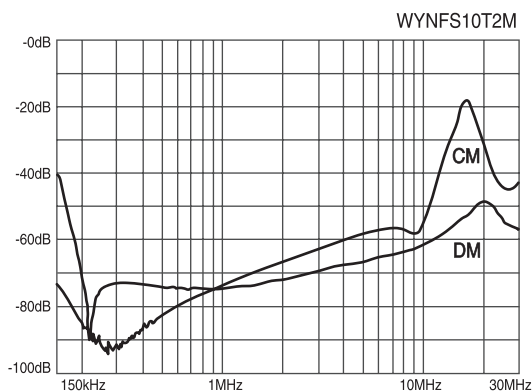
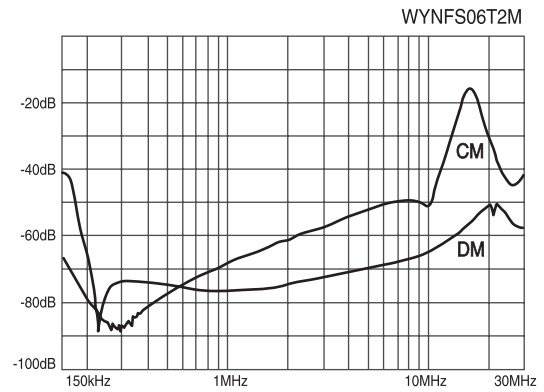
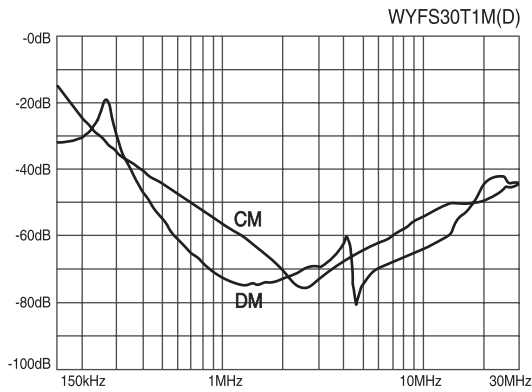
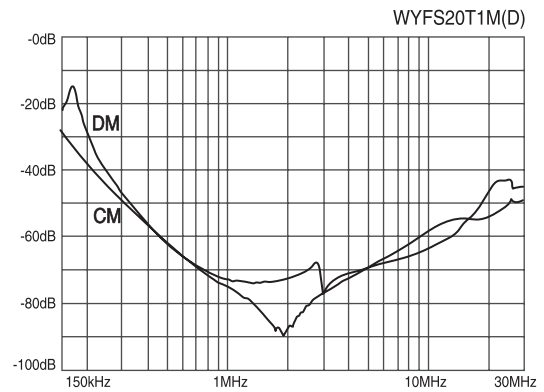
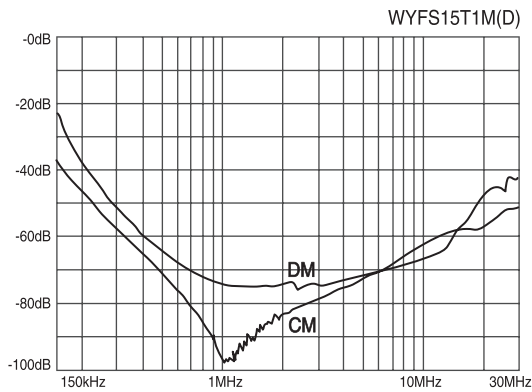
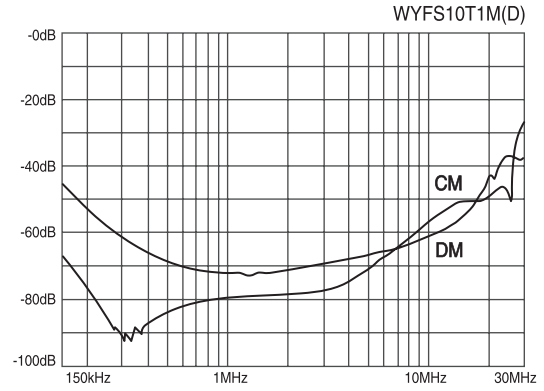
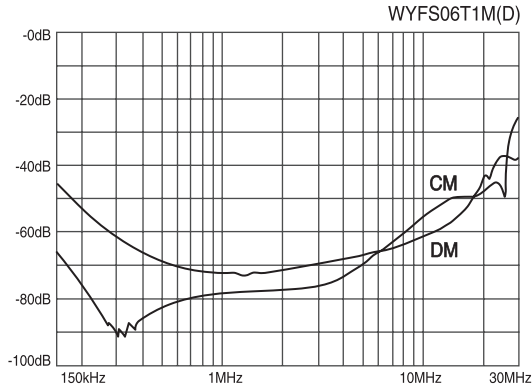

※ CM : Common mode, DM : Differential mode

트랜스포머
REACTOR
리액터
무정전압레일
SSR
전력조정기
TPR
스위칭파워
SMP
노이즈필터
N/F
하모닉필터
H/F
서지보호기
SPD
보호계전기
RELAY
누전경보기
ELD=GF
R
영상변류기
ZCT
판넬메타
METER
계기용변성기
CT=VT
SHUNT=FA
선트팬

● Characteristics

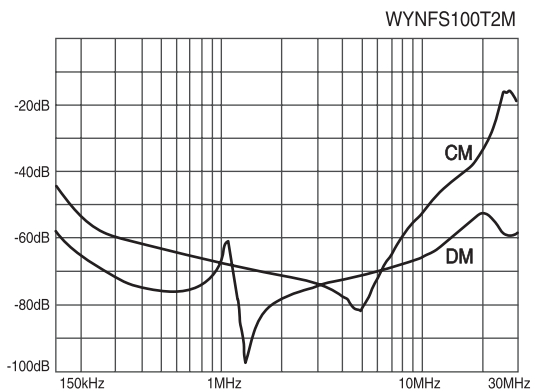
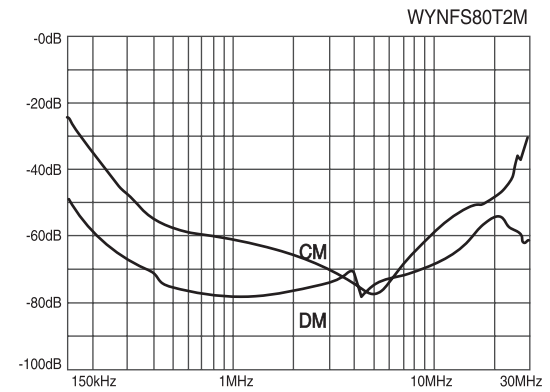
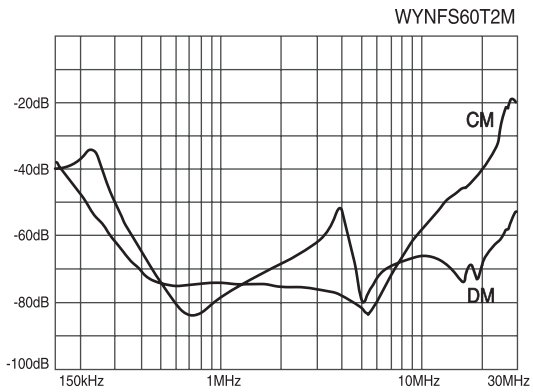
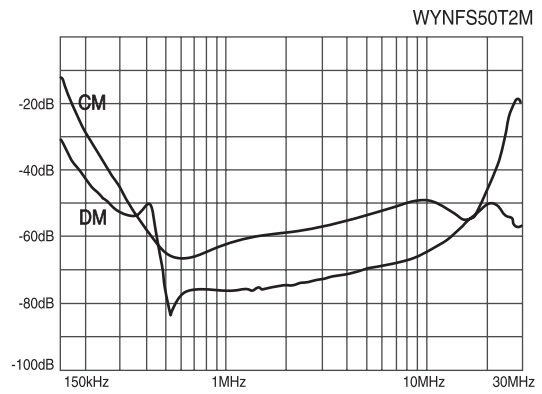
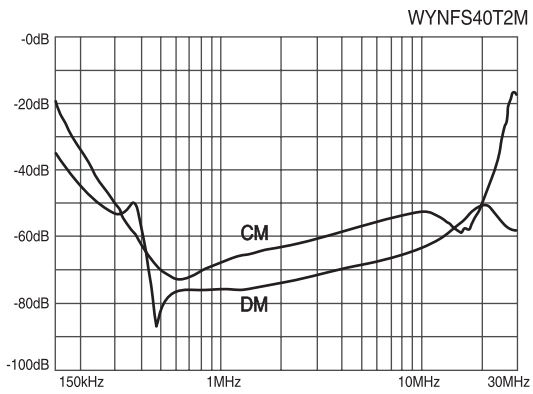
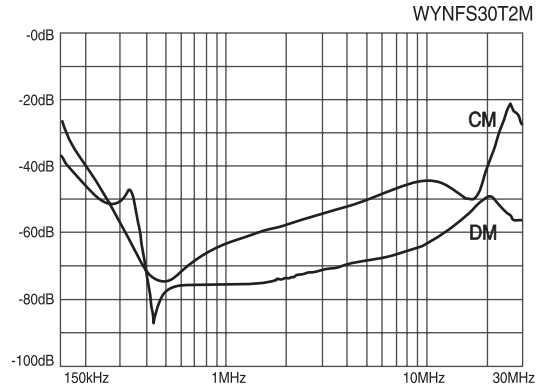
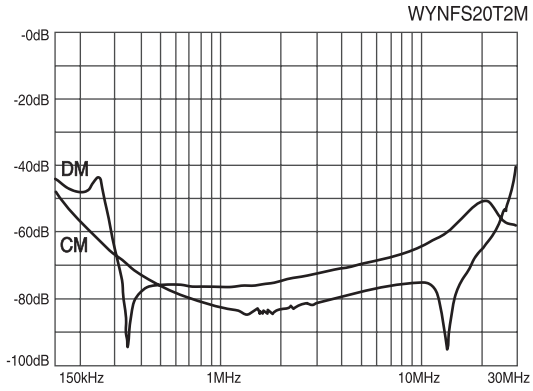

※ CM : Common mode, DM : Differential mode

● Characteristics

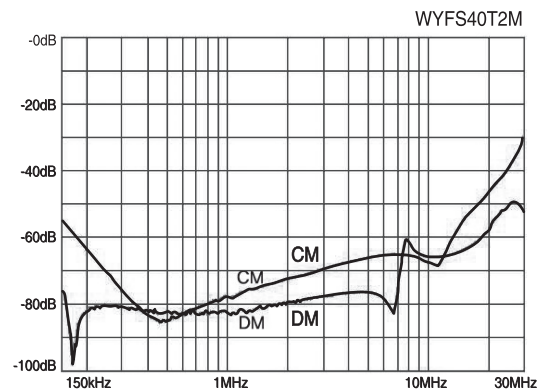
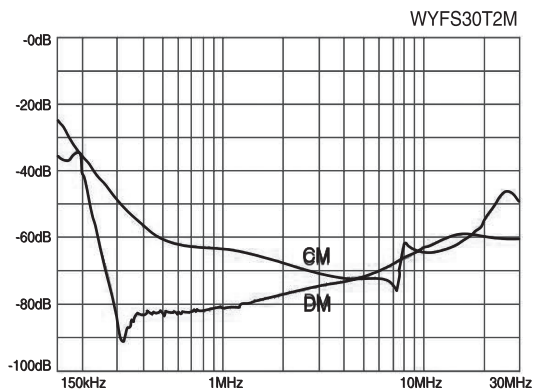
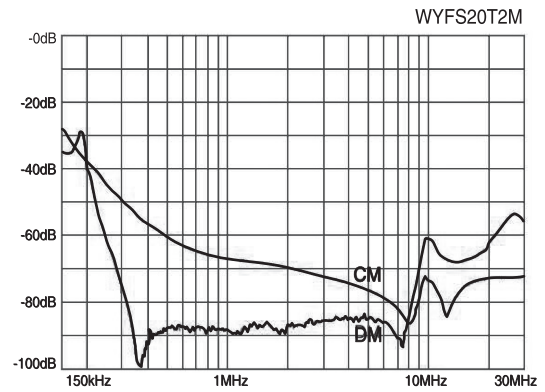
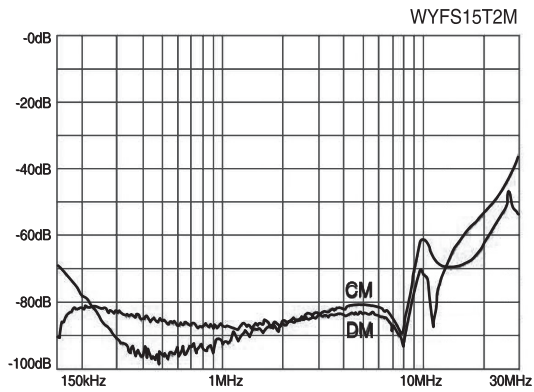
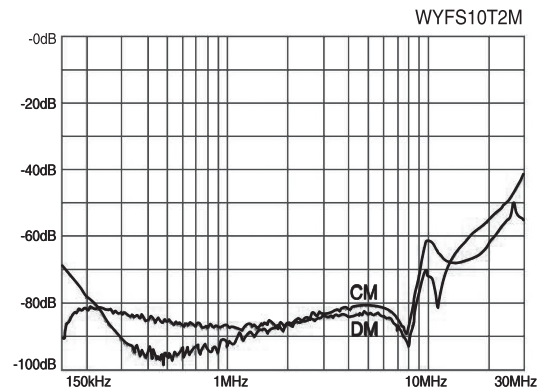
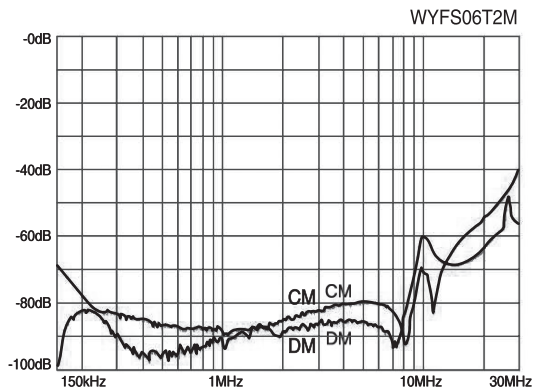
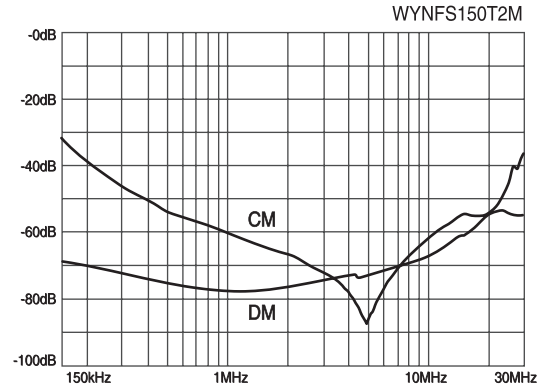
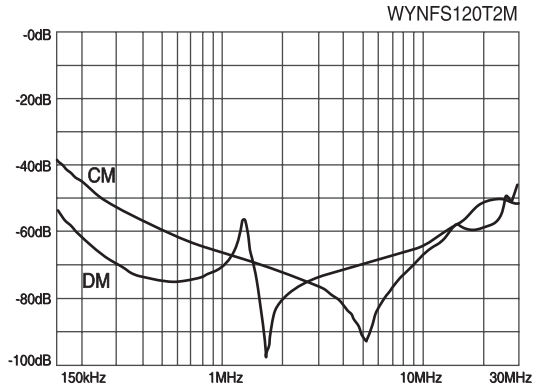

※ CM : Common mode, DM : Differential mode

트랜스포머
REACTOR
리액터
무정전압블레이
SSR
전력조정기
TPR
스위칭파워
SMP
노이즈필터
N/F
하모닉필터
H/F
서지보호기
SPD
보통계전기
RELAY
누전경보기
ELD=GF
영상변류기
ZCT
판넬메타
METER
계기용변성기
CT=VT
SHUNT=FA
선트팬

● Characteristics

