

UL TYPE TRANSFORMER

WY41-UL Series WT Type

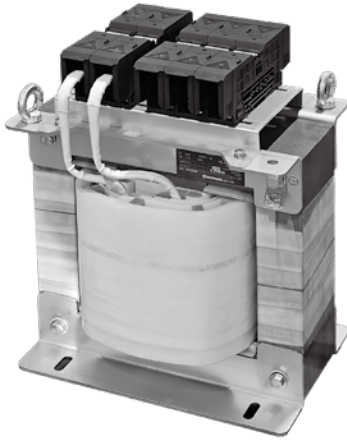

UL 인증



단상 복권형으로 일반 전원 공급용 제품이며 전 규격을 인증 받아 신뢰성과 안전성을 동시에 확보한 제품입니다.

The product, which is a single phase isolation transformer general electric source, has been certified for its proven reliability and safety.

• Circuit Diagram

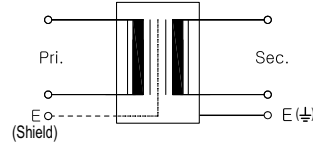

● Standard & Approval

- UL 5085 - 1/2
- UL 1059 (Terminal Block)
- IEC 61558

● Specifications

Insulation Class H

MODEL NO.	TYPE	SPECIFICATIONS		VA	DIMENSIONS (mm)									WEIGHT (kg)
		PRI.(V)	SEC.(V)		W	H	D	a	b	∅	E(Shield)	E(⊥)	M	
WY41-7.5KUL	WT	①380 ②400 ③415 ④440 ⑤460 ⑥480	①100 ②110 ③115 ④120	7.5k	270	397	203	180	173	11 x 35	M6	M5	M8	70.00
WY41-10KUL				10k	310	411	215	219	167	13 x 40	M6	M5	M8	85.00
WY41-15KUL				15k	330	403	269	240	210	11 x 35	M6	M5	M8	110.00
WY41-20KUL				20k	330	438	279	240	220	11 x 35	M6	M5	M10	130.00
WY41-30KUL				30k	350	523	314	250	245	13 x 40	M6	M5	M10	195.00

* 1차, 2차 전압은 주문시 선택

● Dimension

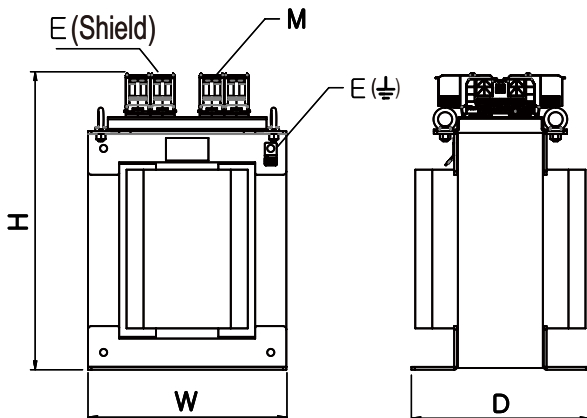

● Terminal

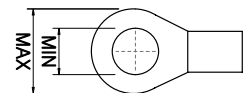

7.5~15kVA : Max 28, Min 8
20~30kVA : Max 39, Min 10

트랜스포머
REACTOR
리액터
무정전압블레이
SSR
전력조정기
TPR
스위칭파워
SMPs
노이즈필터
N/F
하모닉필터
H/F
서지보호기
SPD
보호계전기
RELAY
E
LD = GFR
누전경보기
영상변류기
ZCT
판넬메타
METER
계기용변성기
CT = VT
SHUNT = FAN
선트팬