

# 노이즈필터

Noise Filter

## 1Ø 고감쇄형(Multi-Stage Type)

• 1Ø 250V 6 ~ 150A



# NOISE FILTER

1Ø 250V 고감쇄형 Multi-Stage Type



### ● Features

- 2 Mounting Option
  - WYF\*\*\*\*D : Din Rail Mounting
  - WYF\*\*\*\* : Screw Mounting
- Wide Band : High Attenuation
- Band Width : 150KHz ~ 30MHz
- Low Leakage
- RoHS Compliant
- KC(HK03001-18007A)

### ● Specifications

ITEM	MODEL	SYMBOL	WYFS06T1M (D)	WYFS10T1M (D)	WYFS15T1M (D)	WYFS20T1M (D)	WYFS30T1M (D)
Rated Voltage	V		250				
Rated Current	A		6	10	15	20	30
Frequency	Hz		50 / 60				
Dielectric Withstand	V		2500VAC for 1 minute (Line-Case)				
Insulation Resistance	MΩ		500				
Leakage Current	mA		1.8				
Operating Temperature	°C		-25°C ~ +100°C [Refer to Derating Curve TYPE-1]				
Operating Humidity	RH		35 ~ 85%RH				
Weight	kg		0.2				

※ Derating Curve of page 519

### ● Circuit Diagram

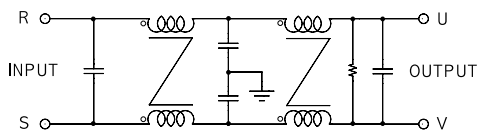

### ● Terminal

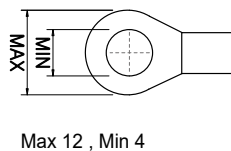

### ● Characteristics

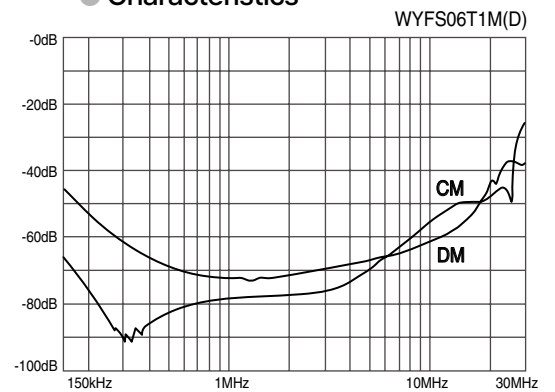

### ● Dimension

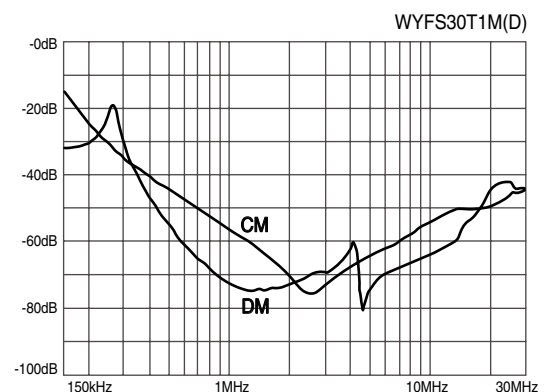
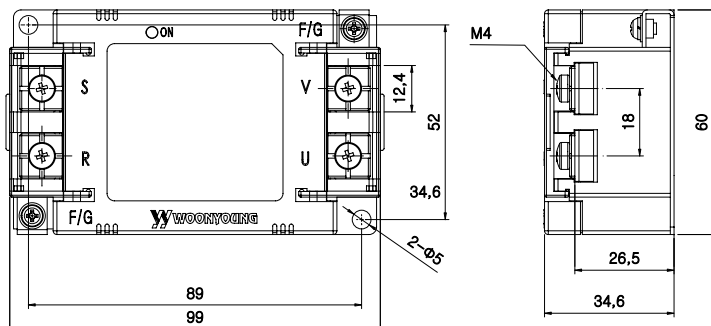

# NOISE FILTER

## N Series 1Ø 250V 고감쇄형 Multi-Stage Type



### ● Features

- Wide Band : High Attenuation
- Band Width : 150KHz ~ 30MHz
- RoHS Compliant

### ● Specifications

ITEM	MODEL	SYMBOL	WYNFS06T2M	WYNFS10T2M	WYNFS15T2M	WYNFS20T2M	WYNFS30T2M	WYNFS40T2M	WYNFS50T2M
Rated Voltage	V		250						
Rated Current	A		6A	10A	15A	20A	30A	40A	50A
Frequency	Hz		50 / 60						
Dielectric Withstand	V		2500VAC for 1 minute (Line-Case)						
Insulation Resistance	MΩ		DC 100MΩ at the 500Vdc						
Leakage Current	mA		≤9mA at the 250Vac						
Operating Temperature	°C		-25°C ~ +100°C [Refer to Derating Curve TYPE-1]						
Operating Humidity	RH		35 ~ 85%RH						
Weight	kg		2.4						

※ Derating Curve of page 519

### ● Circuit Diagram

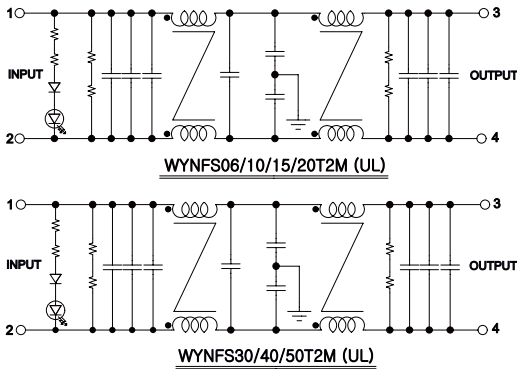

### ● Terminal

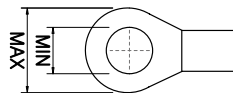

Max 10, Min 4 (6~20A)  
Max 16, Min 5 (30~50A)

### ● Characteristics

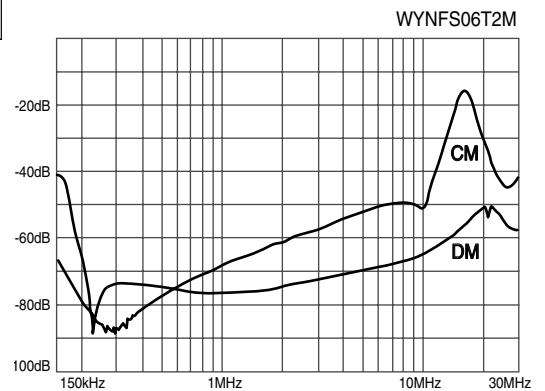

### ● Dimension

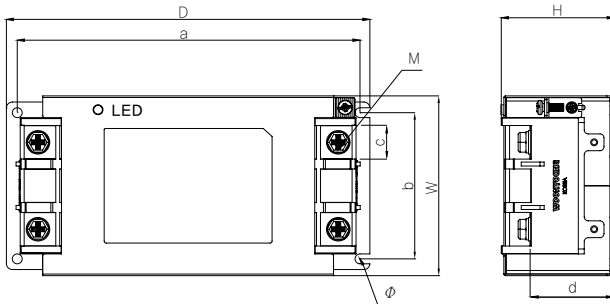

MODEL	W	H	D	a	b	c	d	M	Ø
WYNFS06~20T2M	70.5	45	202	194	51.5	10.5	33	4	5
WYNFS30~50T2M	79.2	48.3	242	232	60	13	33.5	5	5

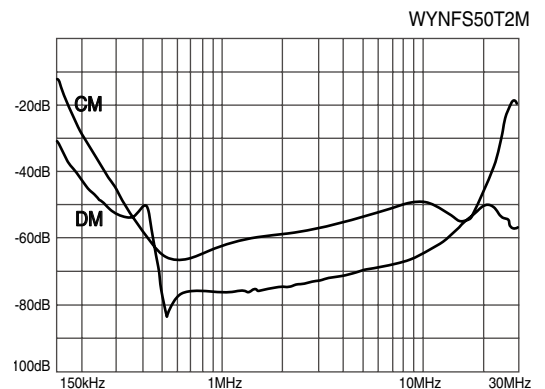

트랜스포머  
REACTOR  
리액터  
무정전압블레이  
SSR  
전력조정기  
TPR  
스위칭파워  
SMP  
노이즈 필터  
H/F  
하모닉 필터  
SPD  
서지보호기  
RELAY  
보호계전기  
E/LD=GF  
영상변류기  
ZCT  
METER  
판넬메타  
계기용변성기  
CT=VT  
SHUNT=FA  
선트랜

# NOISE FILTER

## N Series 1Ø 250V 고감쇄형 Multi-Stage Type



### ● Features

- Wide Band : High Attenuation
- Band Width : 150kHz ~ 30MHz
- RoHS Compliant

### ● Specifications

ITEM	MODEL	SYMBOL	WYNFS60T2M	WYNFS80T2M	WYNFS100T2M	WYNFS120T2M	WYNFS150T2M
Rated Voltage	V		250				
Rated Current	A		60A	80A	100A	120A	150A
Frequency	Hz		50 / 60				
Dielectric Withstand	V		2500VAC for 1 minute (Line-Case)				
Insulation Resistance	MΩ		DC 100MΩ at the 500Vdc				
Leakage Current	mA		≤9mA at the 250Vac				
Operating Temperature	°C		-25°C ~ +100°C [Refer to Derating Curve TYPE-1]				
Operating Humidity	RH		35 ~ 85%RH				
Weight	kg		4.5		5.2		

※ Derating Curve of page 519

### ● Circuit Diagram

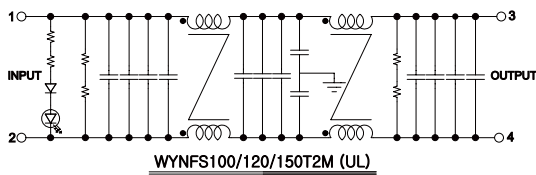
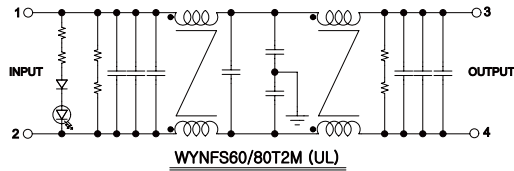

### ● Terminal

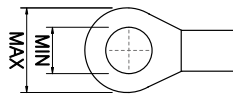

Max 16, Min 6 (60~80A)  
Max 23, Min 8 (100~150A)

### ● Characteristics

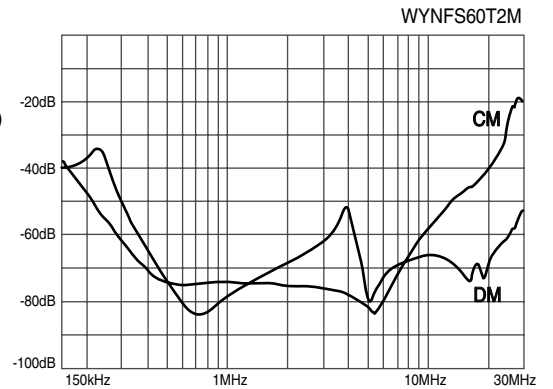

### ● Dimension

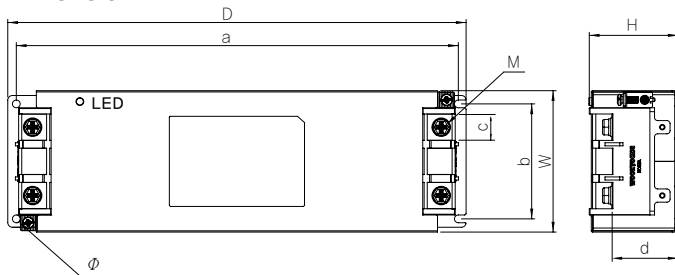

MODEL	W	H	D	a	b	c	d	M	Ø
WYNFS60~80T2M	91	57.2	295	284.5	74	17	42.3	6	5
WYNFS100~150T2M	115	75	384.7	368	96	24	58	8	5

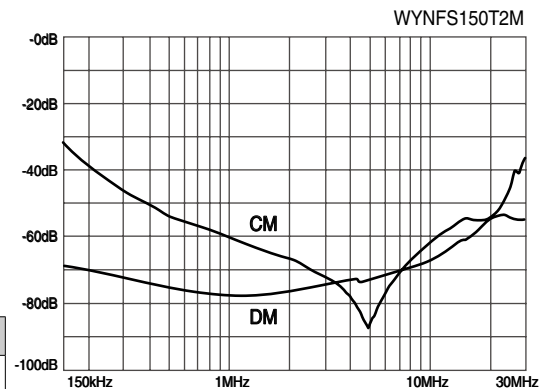

# NOISE FILTER

1Ø 250V 고감쇄형 Multi-Stage Type



### ● Features

- High Attenuation
- High Voltage Pulse Noise
- 2 Stage Filter
- Band Width : 150KHz ~ 30MHz
- RoHS Compliant

### ● Specifications

ITEM \ MODEL	SYMBOL	WYFS06T2M	WYFS10T2M	WYFS15T2M	WYFS20T2M	WYFS30T2M	WYFS40T2M	WYFS50T2M
Rated Voltage	V	250						
Rated Current	A	6	10	15	20	30	40	50
Frequency	Hz	50 / 60						
Dielectric Withstand	V	2500VAC for 1 minute (Line - Case)						
Insulation Resistance	MΩ	500						
Leakage Current	mA	9						
Operating Temperature	°C	-25°C ~ +100°C [Refer to Derating Curve TYPE-1]						
Operating Humidity	RH	35 ~ 85%RH						
Weight	kg	0.8			1.7			

※ Derating Curve of page 519

### ● Circuit Diagram

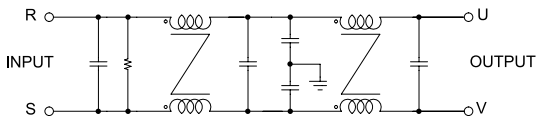

### ● Terminal

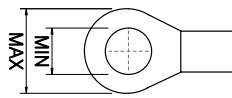

Max 10, Min 4 (6~20A)  
Max 14, Min 4 (30~50A)

### ● Characteristics

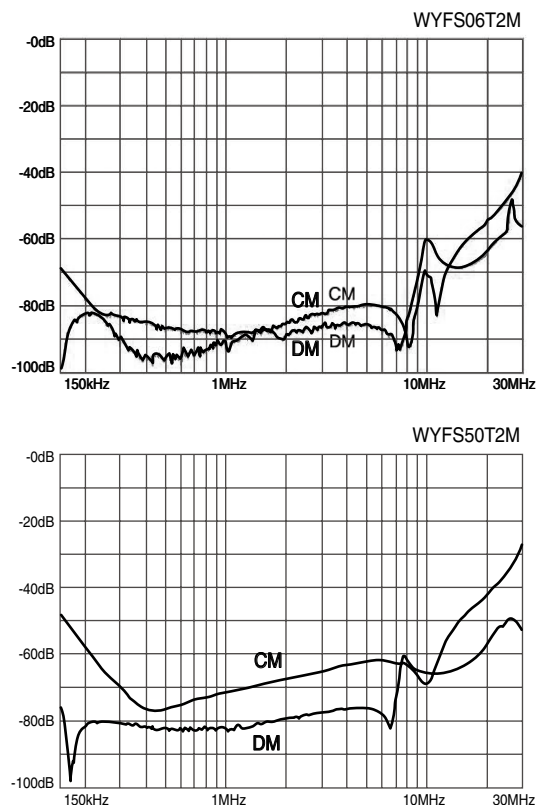

### ● Dimension

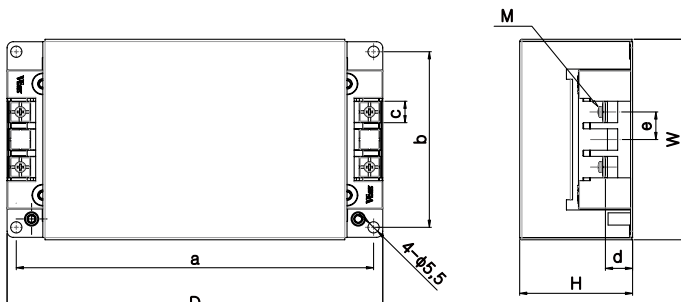

MODEL	W	H	D	a	b	c	d	e
WYFS06~20T2M	98	55	184	175	86	10.5	13	13.5
WYFS30~50T2M	116	75	234	219	98	15	18	27.5

T R A N S = N C T 트랜스포머  
R E A C T O R 리액터  
S S R 무정전압블레이  
T P R 전력조정기  
S M P S 스위칭파워  
N / F 노이즈 필터  
H / F 하모닉 필터  
S P D 서지보호기  
R E L A Y 보호계전기  
E L D = G F R 누전경보기  
Z C T 영상변류기  
M E T E R 판넬메타  
C T = V T 계기용변성기  
S H U N T = F A N 션트팬

# NOISE FILTER

1Ø 250V 고감쇄형 Multi-Stage Type



### ● Features

- High Attenuation
- High Voltage Pulse Noise
- 2 Stage Filter
- Band Width : 150KHz ~ 30MHz
- RoHS Compliant

### ● Specifications

ITEM	MODEL	SYMBOL	WYFS60T2M	WYFS80T2M	WYFS100T2M
Rated Voltage	V		250		
Rated Current	A		60	80	100
Frequency	Hz		50 / 60		
Dielectric Withstand	V		2500VAC for 1 minute (Line-Case)		
Insulation Resistance	M $\Omega$		500		
Leakage Current	mA		9		
Operating Temperature	°C		-25°C ~ +100°C [Refer to Derating Curve TYPE-1]		
Operating Humidity	RH		35 ~ 85%RH		
Weight	kg		2.8		

※ Derating Curve of page 519

### ● Circuit Diagram

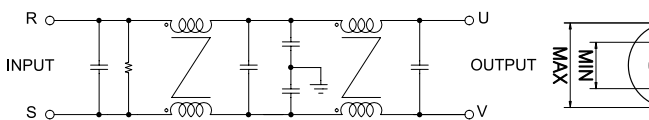

### ● Terminal

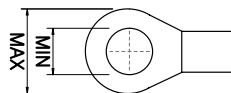

Max 14 , Min 6

### ● Characteristics

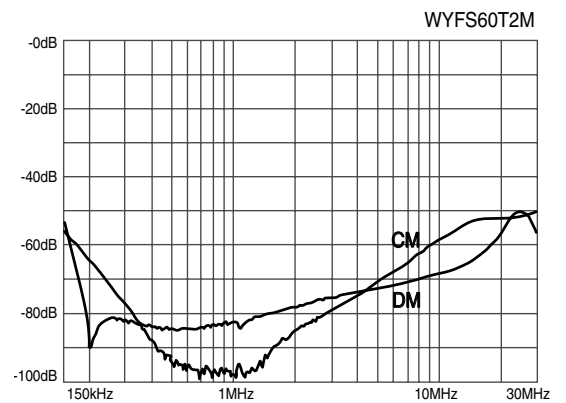

### ● Dimension

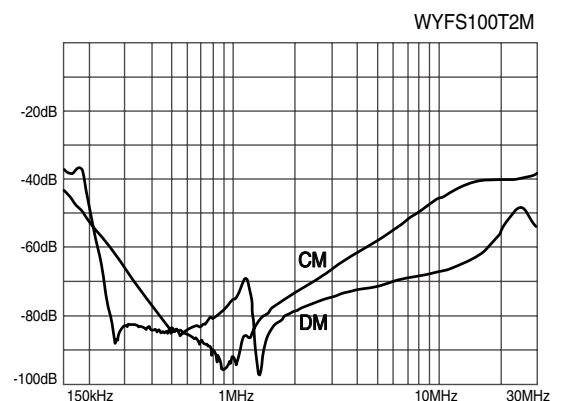
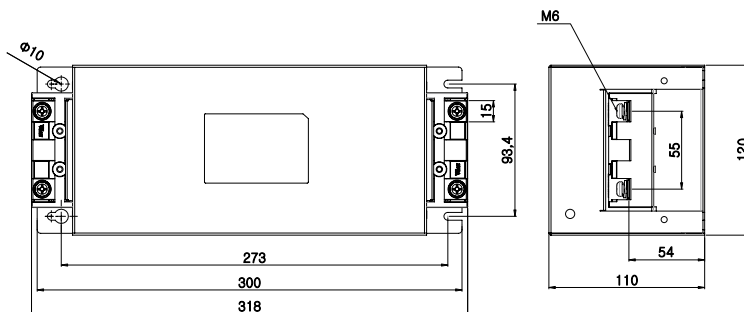

### ● Characteristics

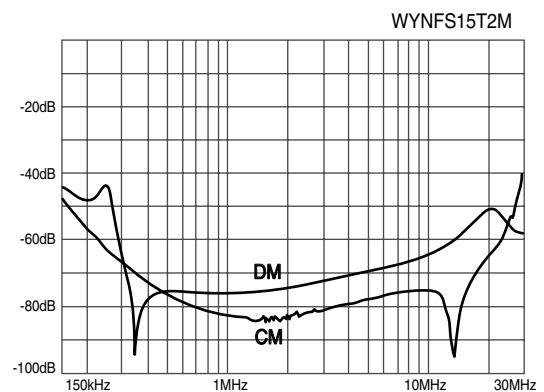
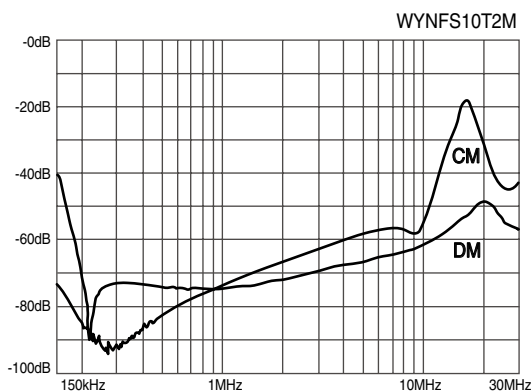
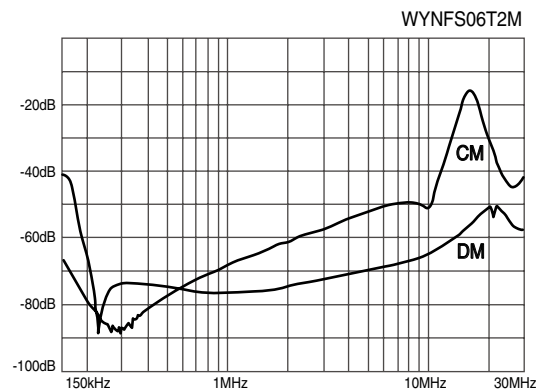
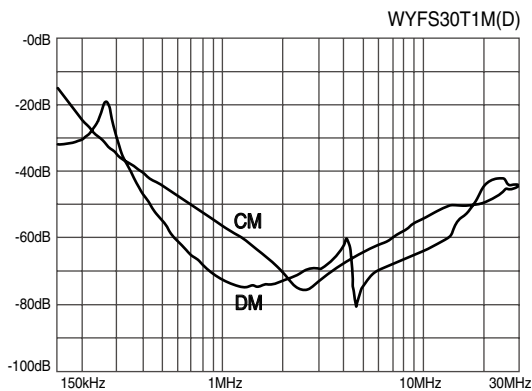
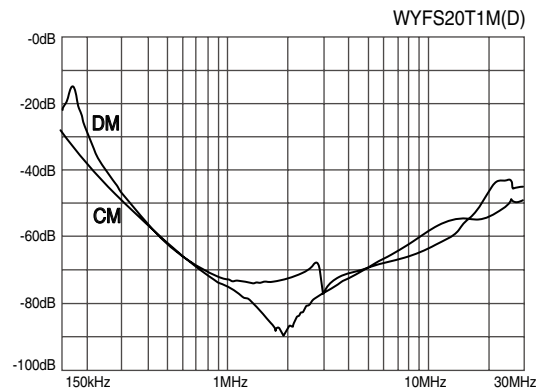
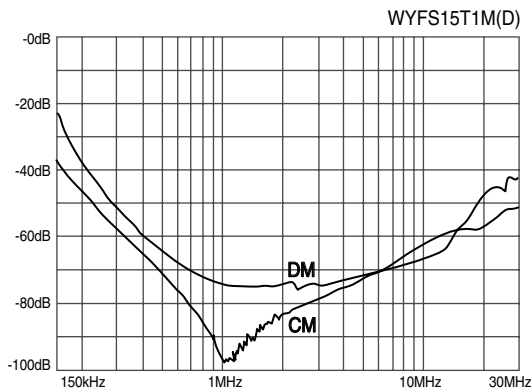
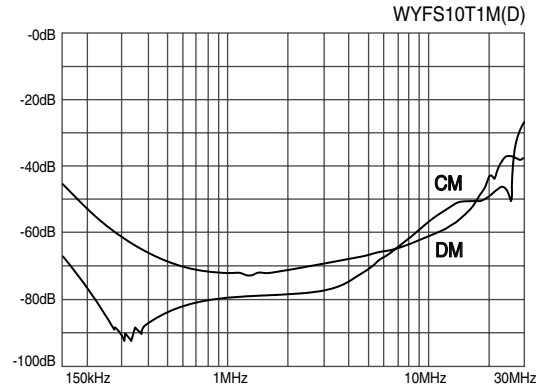
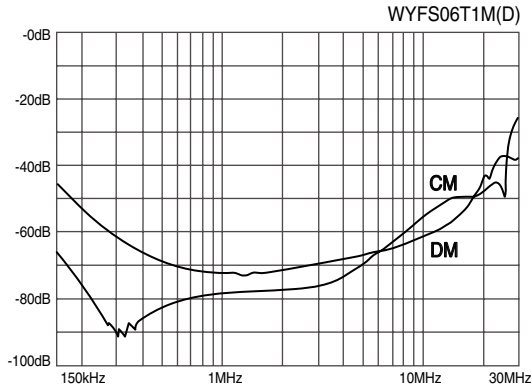

※ CM : Common mode, DM : Differential mode

트랜스포머  
REACTOR  
리액터  
무정전압블레이  
SSR  
전력조정기  
TPR  
스위칭파워  
SMP  
노이즈 필터  
H/F  
하모닉 필터  
서지보호기  
SPD  
보호계전기  
RELAY  
누전경보기  
ELD=GF  
영상변류기  
ZCT  
판넬메타  
METER  
계기용변성기  
CT=VT  
SHUNT=FA  
선트랜

● Characteristics

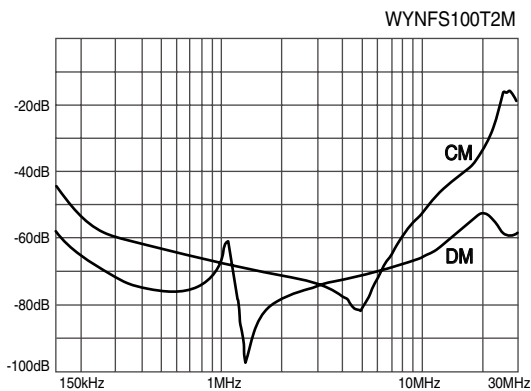
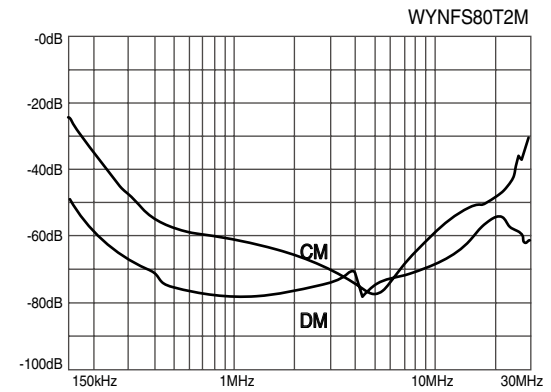
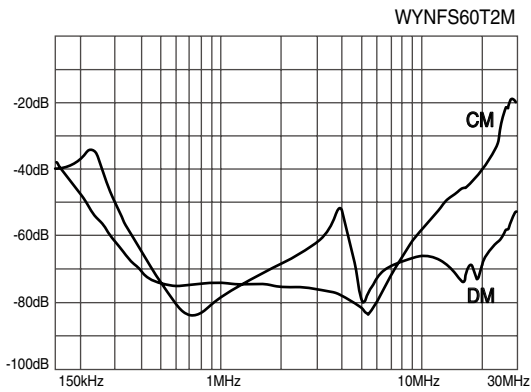
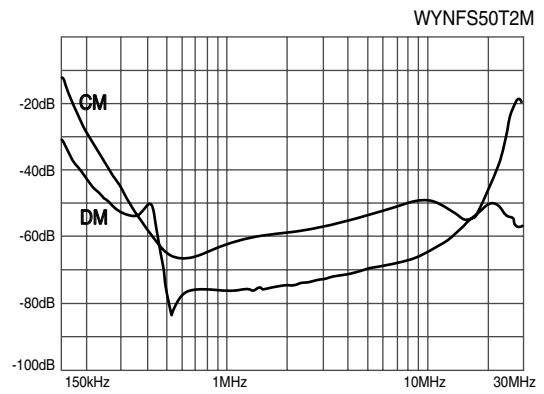
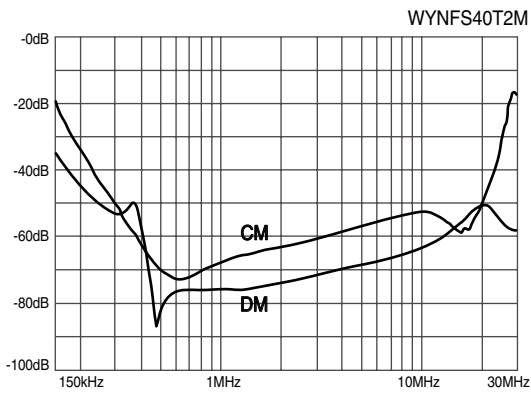
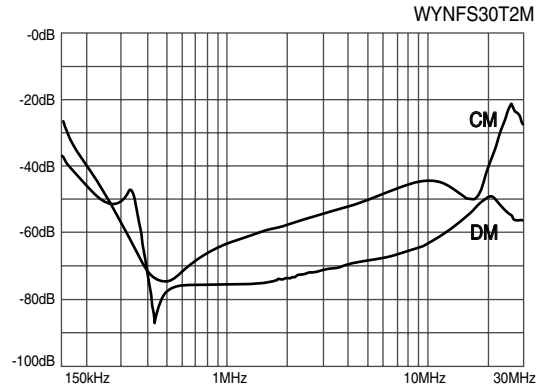
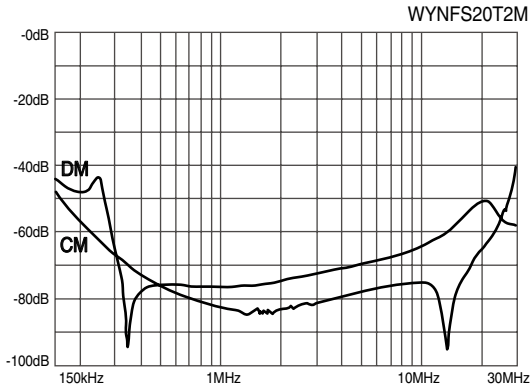

※ CM : Common mode, DM : Differential mode



### ● Characteristics

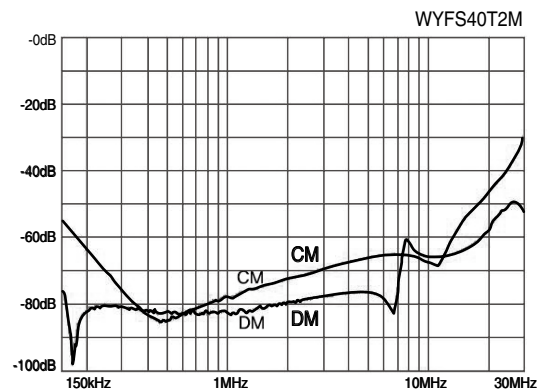
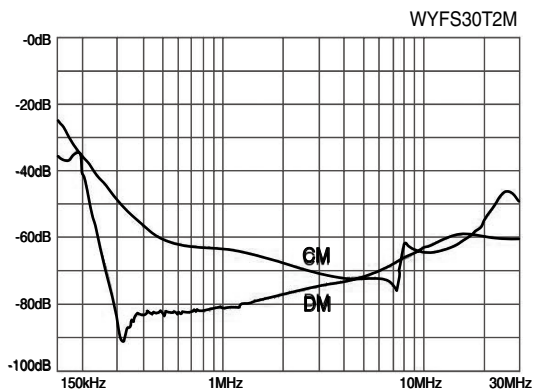
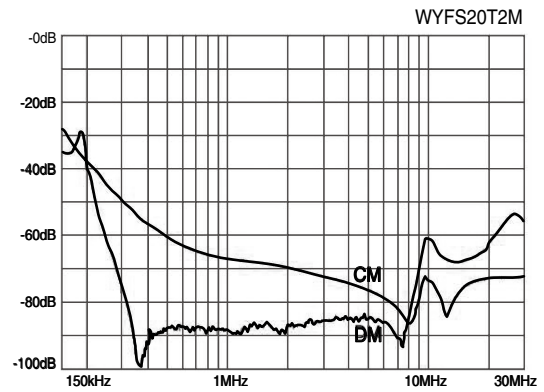
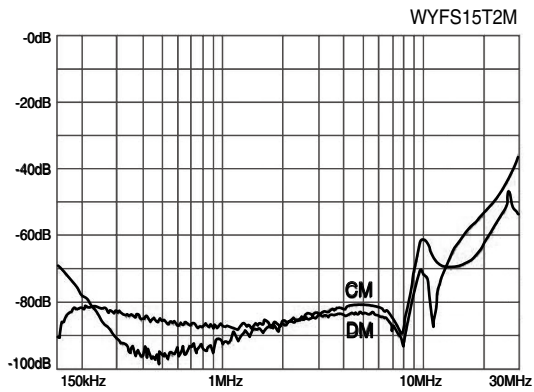
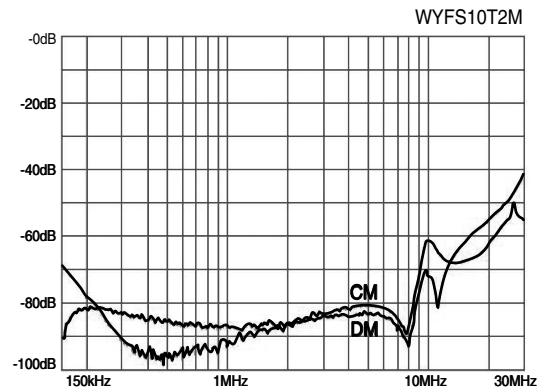
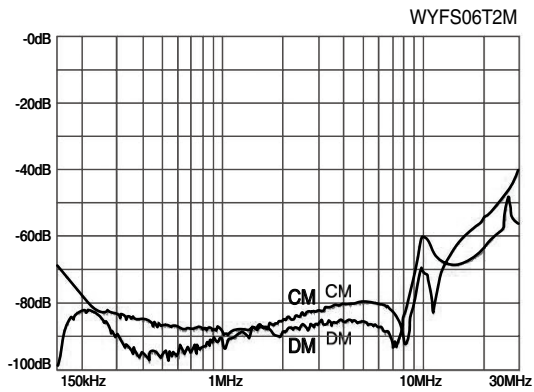
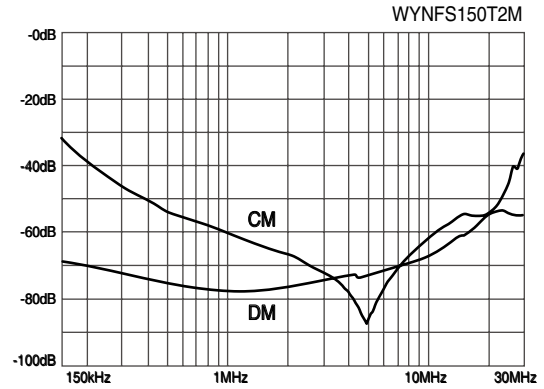
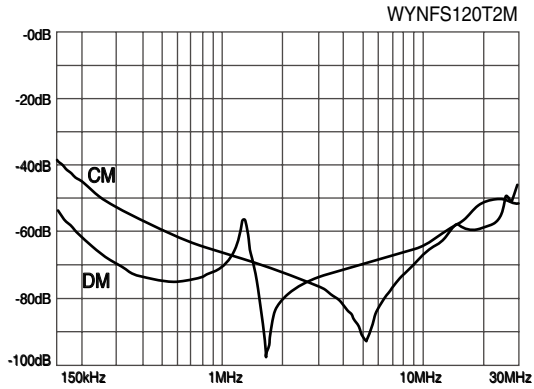

※ CM : Common mode, DM : Differential mode

트랜스포머  
리액터  
무정전압블레이  
전력조정기  
스위칭파워  
노이즈 필터  
하모닉 필터  
서지보호기  
보호계전기  
영상변류기  
판넬메타  
계기용변성기  
선트랜팬

● Characteristics

