

방열판

1. FEATURE

- SSR용 표준 방열판은 다음과 같습니다.
Standard heat sink used on SSR are as follows:

- HS-A1010 : 1Ø 10A Load
- HS-A2020 : 1Ø 20A Load
- HS-A3040 : 1Ø 30A~40A Load
- HS-XXX : 단상, 삼상 공용으로 사용가능 (Can be used on both single-phase and 3-phases)
- 3PHASE : 120mm/10A, 150mm/20A, 200mm/30A, 250mm/40A, 300mm/50A
- H1M-XXX : 1PHASE LOAD
 - 50mm/40A, 70mm/50A, 90mm/60A, 110mm/80A
- H3M-XXX : 3PHASE LOAD
 - 80mm/10~20A, 110mm/30A, 140mm/40A

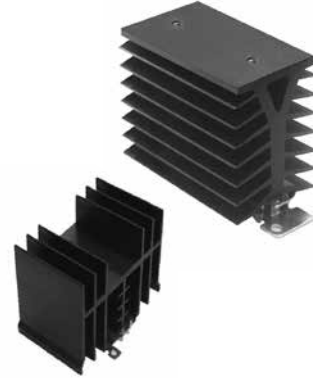

2. HEAT SINK 사용시 주의사항 Caution

- 표준 방열판을 사용하더라도 주위온도가 상승하거나 통풍이 되지 않으면 SSR 파손을 가져올 수 있으므로 주의 바랍니다. (주위온도 : 40°이상)
-If ambient temperature rises or if there is no ventilation even when standard heat sink are used, it may cause damage to SSR. Take precautions (If ambient temperature is 40 °C or higher)
- 보통 SSR 소자의 최대온도는 125°이상일 때 파손되며 방열판의 온도가 80°이상일 때 소자의 온도는 125°에 가까운 온도가 되므로 운전 중 반드시 방열판 온도를 측정하여 주시기 바랍니다.
- In general, power element of SSR is damaged when the maximum temperature of the 125 °C or higher. Since the power element temperature is close to 125 °C when the temperature of the surface of heat sink is 80 °C or higher, check the temperature of heat sink too during operation.
- 표준 방열판에 SSR을 취부할 때는 열 접촉이 원만히 이루어지도록 열전도성 그리스나 SILPAD를 사용하여 주시기 바랍니다.
-When mounting SSR on the standard heat sink, use thermal-conductive grease or SILPAD to ensure satisfactory thermal contact.
- 진동에 풀리지 않도록 규정된 개소를 전부 볼트로 완전히 고정하여 주십시오.
-To prevent bolts from becoming loose due to vibration, tighten up bolts in all prescribed places.
- 단열성 판재 (목판, 프라스틱, 고무)에는 사용하지 말고 반드시 표준 방열기를 이용하여 접촉면에 아래 그림과 같이 방열 그리스를 도포한 후 부착하여 주십시오.
-Do not use on the thermal isolation material (Wood, plastic or rubber) must apply the thermal grease on the contact surface as shown in Figure below and mounting on the standard heat sink.

※ 그림과 같이 방열 실리콘 그리스를 방열기와 SSR 밑면에 골고루 도포하여 고정된 후 방열기의 끝이 상하로 향하도록 장치에 고정하십시오.

- As shown in Figure, evenly apply thermal conductive silicon grease to the heat sink and the bottom of SSR, and fix it in a way that vertical of heat sink fin.

- 권장 실리콘 그리스 (Suggested silicon grease) : TOSHIBA YG6111
신에츠(shinetsu) G766

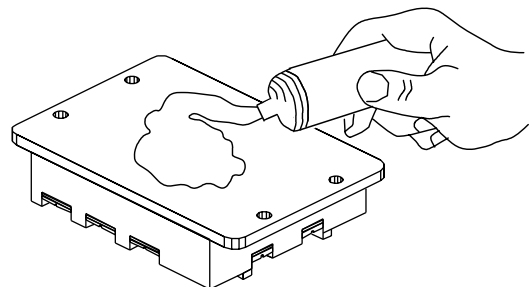

트랜스포머
REACTOR
리액터
무점멸플래이
SSR
전력조정기
TPR
스위칭파워
SMP
노이즈필터
NF
하모닉필터
HF
서지보호기
SPD
보호계전기
RELAY
누전경보기
ELD=GF
R
영상변류기
ZCT
판넬메타
METER
계기용변성기
CT=VT
선트팬
SHUNT=FAN

HEAT SINK

DIN-Rail 겸용 방열판

● Dimension

HS - A1010 1Ø 10A-DIN Rail type

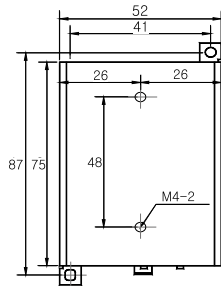

※ Weight : 0.23 kg

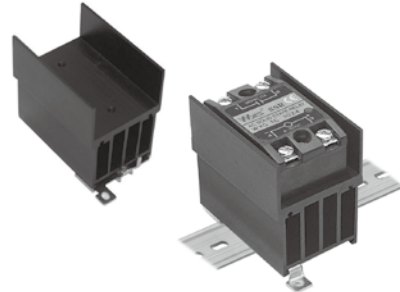
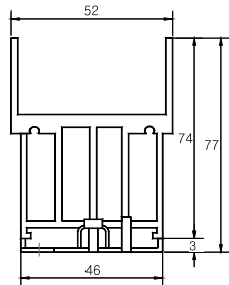

HS-A1040 1Ø 10~40A-DIN RAIL TYPE

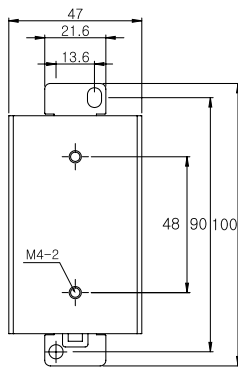

※ Weight : 0.27 kg

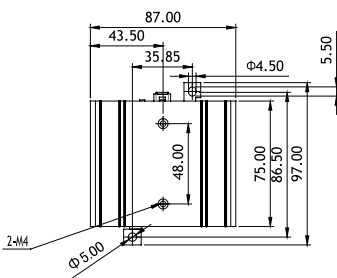
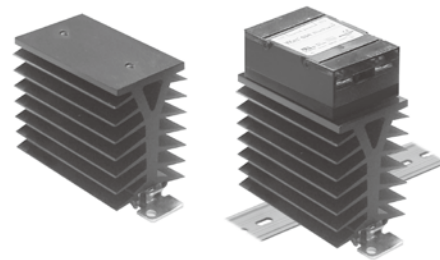
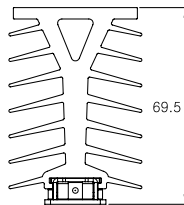

※ Weight : 0.45 kg

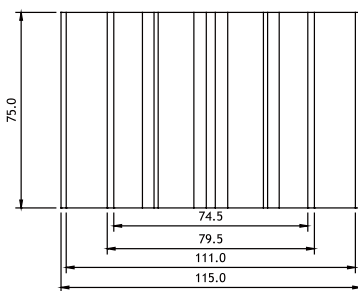
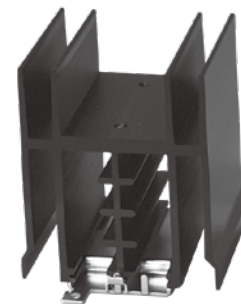
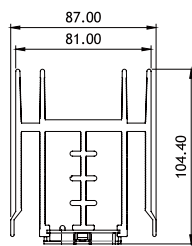

※ Weight : 0.58 kg

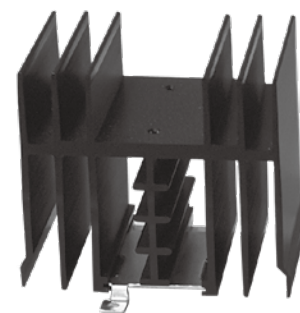
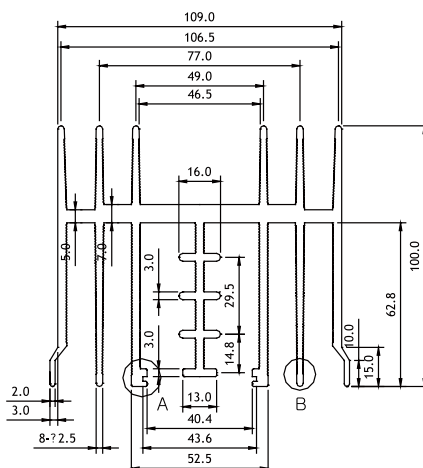

방열판

● Dimension

H1M - XXX(mm) 1Ø 40~80A

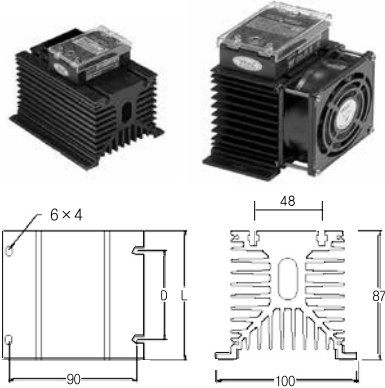

80X80X25mm
CFM morethan30

MODEL	H1M-50	H1M-70	H1M-90	H1M-110
길이(Leangth) L	50mm	70mm	90mm	110mm
고정홀치수(D)	Center(중앙)	50mm	60mm	60mm
1Phase SSR Rating	40A	50A	60A	80A
FAN - SSR Rating	50~60A	80A	-	-
Weight	1.6kg	1.8kg	1.2kg	1.5kg

H3M - XXX(mm) 3Ø 10~80A

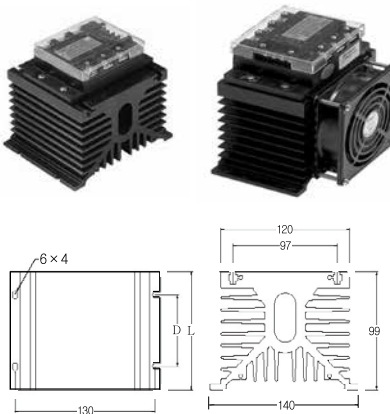

FAN : 92X92X25mm
CFM more than 30

MODEL	H3M-80	H3M-110	H3M-140
길이(Leangth) L	80mm	100mm	140mm
고정홀치수(D)	60mm	60mm	90mm
3Phase SSR Rating	10~20A	30A	40A
FAN SSR Rating	30~50A	60A	80A
Weight	1.1kg	1.5kg	1.9kg

HS -XXX (mm) 3Ø 10~30A

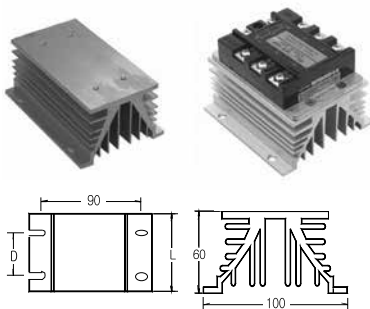

MODEL	HS-120	HS-150	HS-200	HS-250	HS-300
길이(Leangth) L	120mm	150mm	200mm	250mm	300mm
고정홀치수(D)	70mm	100mm	150mm	200mm	250mm
3Phase SSR Rating	10A	20A	30A		
Weight	0.6kg	0.7kg	0.85kg	1.15kg	1.35kg

T R A N S = N C T 트랜스포머
 R E A C T O R 리액터
 S S R 무접점릴레이
 T P R 전력조정기
 S M P S 스위칭파워
 N / F 노이즈필터
 H / F 하모닉필터
 S P D 서지보호기
 R E L A Y 보호계전기
 E L D = G F R 누전경보기
 Z C T 영상변류기
 M E T E R 판넬메타
 C T = V T 계기용변성기
 S H U N T = F A N 션트팬