



Specifications

- Input voltage : AC220V
- Output voltage : AC220V
- Frequency : 50/60 Hz
- Capacity : 300VA ~ 5kVA
- Insulation resistance : 100MΩ 이상 / DC500V
- Dielectric withstand : AC3000V / 1min
- Oper. temperature : 0 ~ 50℃
- Oper. humidity : 30 ~ 95%

Connector Type

MODEL	VA	DIMENSIONS (mm)						WEIGHT (kg)
		W	H	D	a	b	Ø	
WYNC22-300C	300	120	138	155	122	105	7 x 10	7.9
WYNC22-500C	500	144	162	190	140	130	7 x 10	13
WYNC22-1KC	1K	171	191	240	170	133	7 x 10	20
WYNC22-1.5KC	1.5K	203	229	210	207	124	7 x 10	28
WYNC22-2KC	2K	203	229	210	207	124	7 x 10	35
WYNC22-3KC	3K	204	258	230	207	140	9 x 15	40
WYNC22-5KC	5K	204	258	260	207	180	9 x 15	54

※기타 : 주문에의함.(Option)

제품 주요 용도(Major applications)

- 반도체 제조 장비의 전원 공급용
- 정밀 계측기의 전원 공급용
- 의료기, 철도, 전산센터등의 주전원 공급용
- 교통망 신호 제어등의 전원 Line
- 노이즈 발생이 심한 전원 Line
- MICOM 제어기기, PLC, OA, FA 기기의 전원 공급용
- Supply power to the semiconductor manufacturing equipment.
- Supply power to precision meters
- Supply main power to medical devices, railroads and computer center.
- Power supply line for transportation network signal control.
- Power supply line producing high level of noise.
- Supply power to Micom controls and PLC, OA and FA equipment.

Connection Diagram

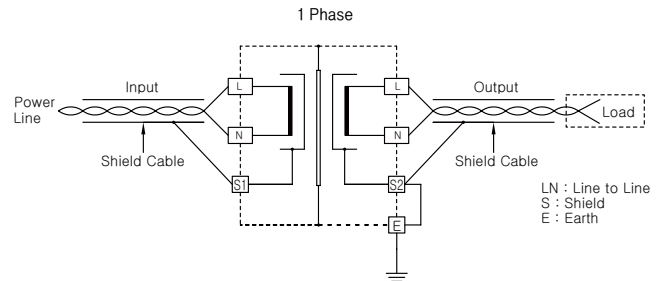

Input Connector Pin Connection

- Pin-1 : 0 V
- Pin-2 : 220 V
- Pin-3 : Shield
- Pin-4 : E (Earth)

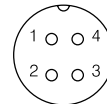

Dimension

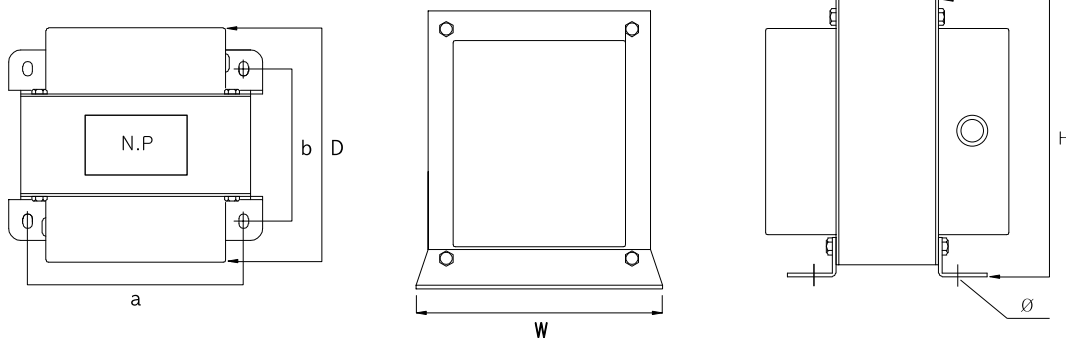

트랜스포머
REACTOR
리액터
무정전압릴레이
SSR
전력조정기
TPR
스위칭파워
SMP
노이즈필터
N/F
하모닉필터
H/F
서지보호기
SPD
보호계전기
RELAY
E
LD
=
GF
R
영상변류기
ZCT
판넬메타
METER
계기용변성기
CT=VT
SHUNT=FA
선트팬