

ROUND TYPE (환형) CURRENT TRANSFORMER

0.72~1.2kV (50~1500A)

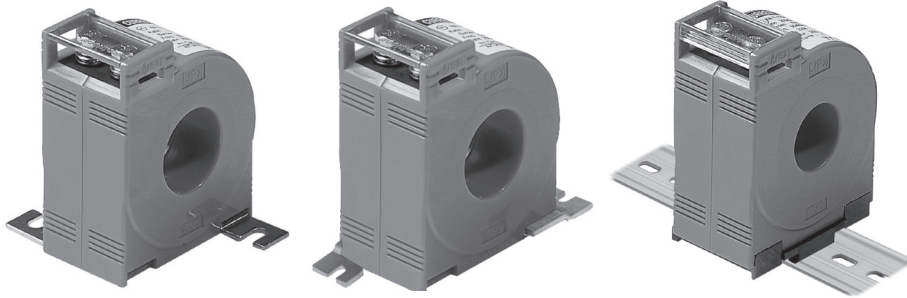

- Standard :KS C 1706, IEC 61869-2, JEC 1201, IEEE C 57.13



CR "A" TYPE

CR "B" TYPE

Din-Rail

● Specifications

- Ring type C,T
- Maximum voltage : 0.72~1.2kV
- Over current strength : 40In/1sec.
- Frequency : 50Hz or 60Hz
- Standard : CR "A" Type
- Option : CR "B" Type, Din-Rail Type

● Features

- Protect cover
- Easy to install panel mounting kit
- DIN rail mounting for ease of installation

● Specifications

Model	Primary (A)	Secondary (A)	Burden (VA)	Class (%)	Weight (kg)	Hole size (φ)
WYCR-15	50~75	5 or 1	2.5	1.0	≒0.5	15
	100~200		5	1.0	≒0.6	
WYCR-27	50~80		2.5	3.0	≒0.5	27
	80		2.5	1.0		
	100		5	3.0		
	100		5	1.0		
WYCR-30	50~75		2.5	3.0	≒0.4	30
	100~300		5	3.0		
	100~300		5	1.0		
	200~300		15	1.0		
WYCR-40	200~600	5	1.0	≒0.3	40	
	400~600	15	1.0			
WYCR-60	100~1500	5	1.0	≒1.0	60	
	200~1500	15	1.0			
	400~1500	40	1.0			

● Connection Diagram

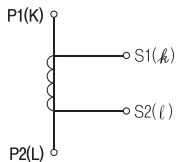

● Dimension

unit : (mm)

Model	A	B	C	D	E	F	H	TYPE
WYCR-15, 27, 30, 40	60	76	39	70	60	50	84	A
WYCR-60	60	76	57	114	60	80	112	
WYCR-15, 27, 30, 40	22	46	39	70	22	83	84	B

트랜스포머
계기용변성기
리액터
무전선출력레이
전력조정기
스위칭파워
노이즈필터
하모닉필터
서지보호기
보호계전기
영상변류기
판넬메타
계기용변성기
선트팬

ROUND TYPE (환형) CURRENT TRANSFORMER

0.72~1.2kV (5~30A)

● Illustration & Drawing

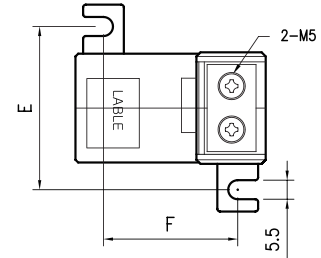
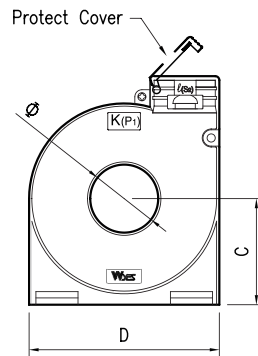
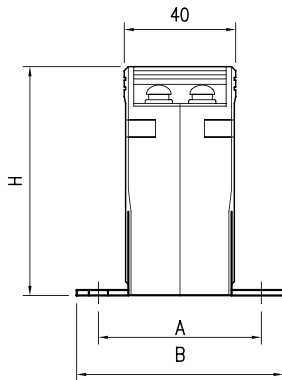

CR "A" TYPE - 15, 27, 30, 40

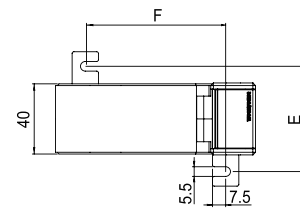
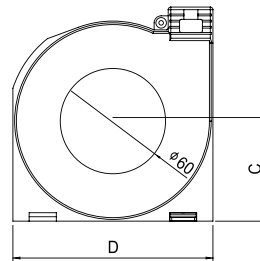
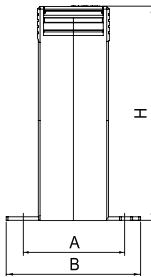

CR "A" TYPE - 60

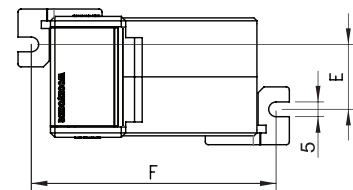
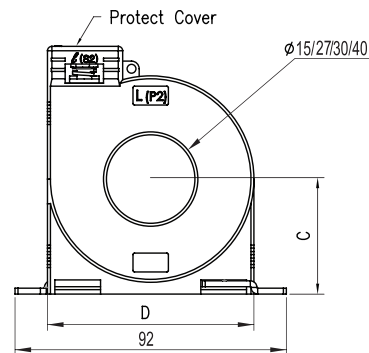
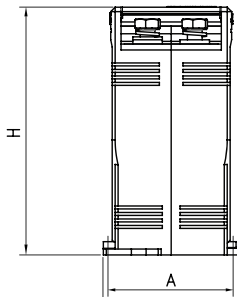

CR "B" TYPE - 15, 27, 30, 40

ROUND TYPE (환형) CURRENT TRANSFORMER

0.72~1.2kV (5~1500A)



Primary Turns

Model	WYCR-15				WYCR-27, 30						WYCR-40				WYCR-60					
Class	1.0%				3.0%		1.0%				1.0%				1.0%					
Burden	2.5VA		5VA		5VA		5VA		15VA		5VA		15VA		5VA		15VA		40VA	
A/T Pri.	A/T	Tur.	A/T	Tur.	A/T	Tur.	A/T	Tur.	A/T	Tur.	A/T	Tur.	A/T	Tur.	A/T	Tur.	A/T	Tur.	A/T	Tur.
5A	50	10	100	20	100	20	100	20	-	-	200	40	-	-	-	-	-	-	-	-
10A	50	5	100	10	100	10	100	10	-	-	200	20	-	-	-	-	-	-	-	-
15A	60	4	120	8	120	8	120	8	240	16	240	16	-	-	-	-	-	-	-	-
20A	60	3	100	5	100	5	100	5	200	10	200	10	-	-	-	-	-	-	-	-
25A	50	2	100	4	100	4	100	4	200	8	200	8	-	-	-	-	-	-	-	-
30A	60	2	120	4	120	4	120	4	240	8	240	8	-	-	-	-	-	-	-	-
40A	80	2	120	3	120	3	120	3	200	5	240	6	-	-	-	-	-	-	-	-
50A	50	1	100	2	100	2	100	2	200	4	200	4	-	-	-	-	-	-	-	-
60A	60	1	120	2	120	2	120	2	240	4	240	4	-	-	-	-	-	-	-	-
75A	75	1	150	2	75	2	150	2	225	3	200	4	-	-	-	-	-	-	-	-
80A	80	1	-	-	80	3	240	3	240	3	240	3	-	-	-	-	-	-	-	-
100A	-	-	100	1	100	1	100	1	200	2	200	2	-	-	100	1	-	-	-	-
120A	-	-	120	1	100	1	100	1	240	2	240	2	-	-	120	1	-	-	-	-
150A	-	-	150	1	150	1	150	1	300	2	300	2	-	-	150	1	-	-	-	-
200A	-	-	200	1	200	1	200	1	200	1	200	1	-	-	200	1	200	1	-	-
240A	-	-	-	-	240	1	200	1	240	1	240	1	-	-	240	1	240	1	-	-
250A	-	-	-	-	250	1	200	1	250	1	250	1	-	-	250	1	250	1	-	-
300A	-	-	-	-	300	1	200	1	300	1	300	1	300	1	300	1	300	1	-	-
400A	-	-	-	-	-	-	-	-	-	-	400	1	400	1	400	1	400	1	400	1
500A	-	-	-	-	-	-	-	-	-	-	500	1	500	1	500	1	500	1	500	1
600A	-	-	-	-	-	-	-	-	-	-	600	1	600	1	600	1	600	1	600	1
750A	-	-	-	-	-	-	-	-	-	-	-	-	-	750	1	750	1	750	1	
800A	-	-	-	-	-	-	-	-	-	-	-	-	-	800	1	800	1	800	1	
1000A	-	-	-	-	-	-	-	-	-	-	-	-	-	1000	1	1000	1	1000	1	
1200A	-	-	-	-	-	-	-	-	-	-	-	-	-	1200	1	1200	1	1200	1	
1500A	-	-	-	-	-	-	-	-	-	-	-	-	-	1500	1	1500	1	1500	1	

CT(VA)에 대한 필요 전선 길이

CT 2차 전선굵기 (mm ²)	CT 용량(VA)에대한 필요 전선 길이							
	CT 2차 / 5A에대한 용량(VA)							
	1m	2m	4m	6m	8m	10m	15m	20m
2 x 0.5	1.837	3.67	7.35	11.02	-	-	-	-
2 x 0.75	1.235	2.47	4.94	7.41	9.88	-	-	-
2 x 1.0	0.918	1.84	3.67	5.51	7.34	9.18	-	-
2 x 1.5	0.613	1.23	2.45	3.68	4.90	6.13	9.20	-
2 x 2.5	0.368	0.74	1.47	2.21	2.94	3.68	5.52	7.36
2 x 4.0	0.233	0.47	0.93	1.40	1.86	2.33	3.50	4.66
2 x 6.0	0.149	0.30	0.60	0.89	1.19	1.49	2.23	2.98

트랜스포머
REACTOR
리액터
무점접촉변압기
SSR
전력조정기
스위칭파워
SMP
노이즈필터
N/F
하모닉필터
H/F
서지보호기
SPD
보호계전기
RELAY
누전경보기
ELD=GFR
영상변류기
ZCT
판넬메타
METER
계기용변성기
CT=VT
선트랜팬
SHUNT=FA