



● Features

- 2 Mounting Option
 - WYF****D : Din Rail Mounting
 - WYF**** : Screw Mounting
- Wide Band : High Attenuation
- Band Width : 150KHz~30MHz
- Low Leakage
- RoHS Compliant
- KC(안전인증) Approved by HK03001-19008A (Without "C" Type)
- Inverter Output Type : Model Type"C" (WYFTH05T1C)

● Specifications

ITEM	MODEL	SYMBOL	WYFTH05T1A (D) WYFTH05T1C(D)	WYFTH10T1A (D) WYFTH10T1C (D)	WYFTH15T1A (D) WYFTH15T1C (D)	WYFTH20T1A (D) WYFTH20T1C (D)	WYFTH30T1A (D) WYFTH30T1C (D)
Rated Voltage	V		500				
Rated Current	A		5	10	15	20	30
Frequency	Hz		50/60				
Dielectric Withstand	V		2500Vac for 1 minute or 2150Vdc for 1 minute				
Insulation Resistance	MΩ		DC 100MΩ at the 500Vdc				
Leakage Current	mA		≤4,0				
Operating Temperature	℃		-25℃ ~ +100℃ [Refer to Derating Curve TYPE-2]				
Operating Humidity	RH		35~85%RH				
Weight	kg		0,5				

※ "D" : DIN-Rail type of page 184, "C" : Inverter Output Type / Derating Curve of page 103

● Circuit Diagram

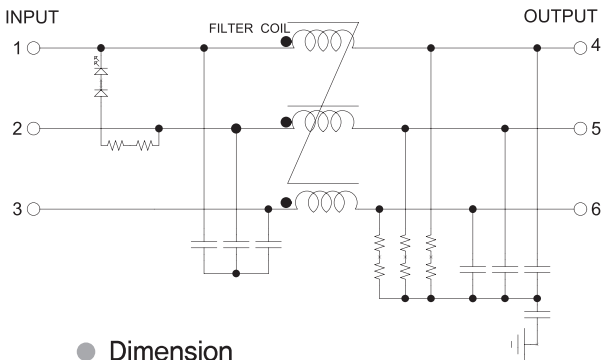

● Terminal

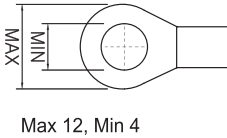

● Characteristics

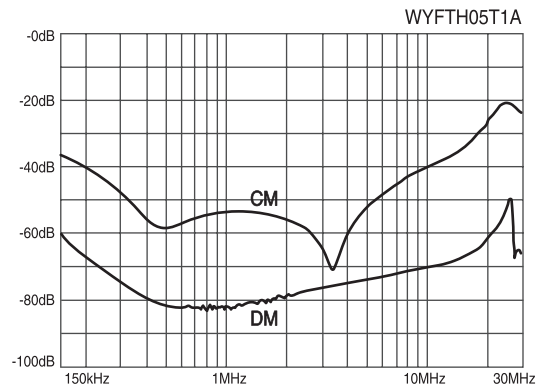

● Dimension

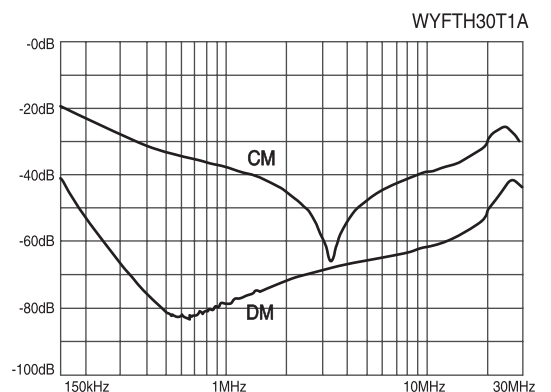
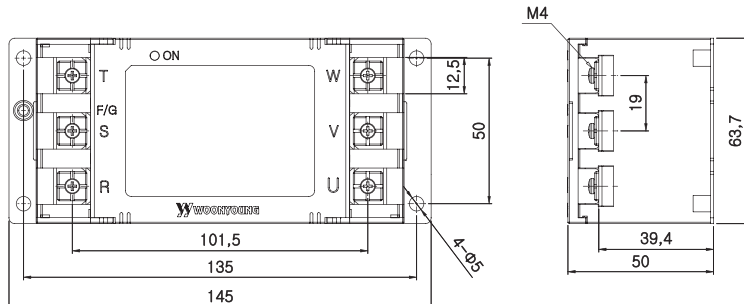

● Characteristics

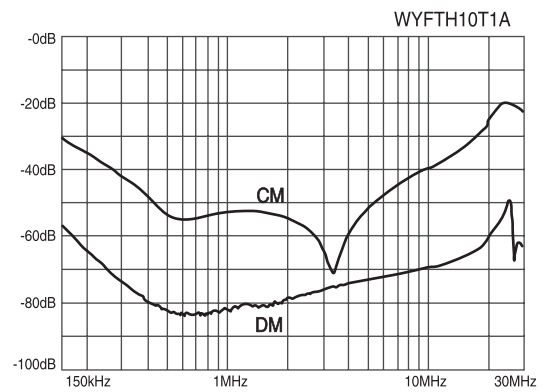
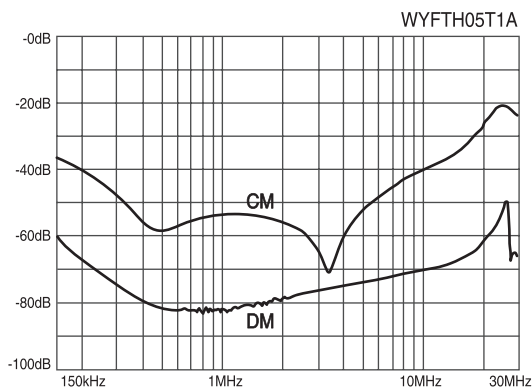
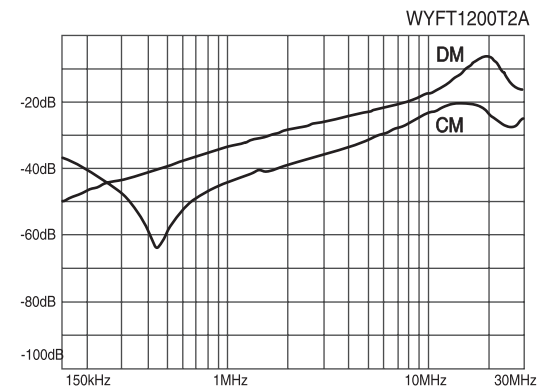
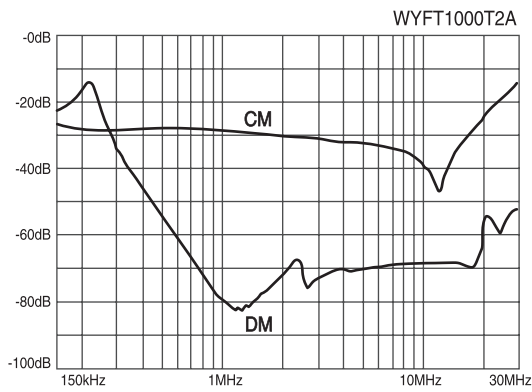
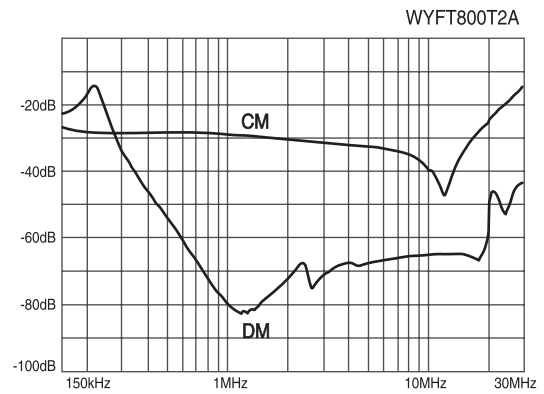
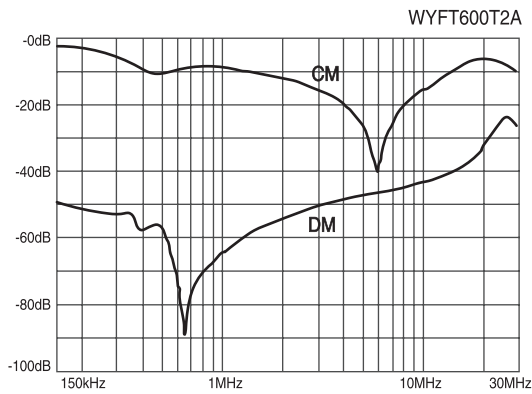
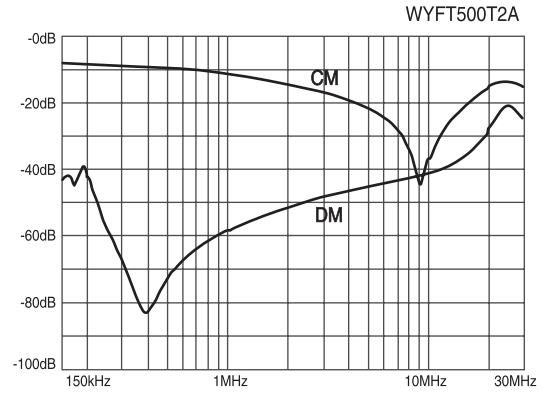
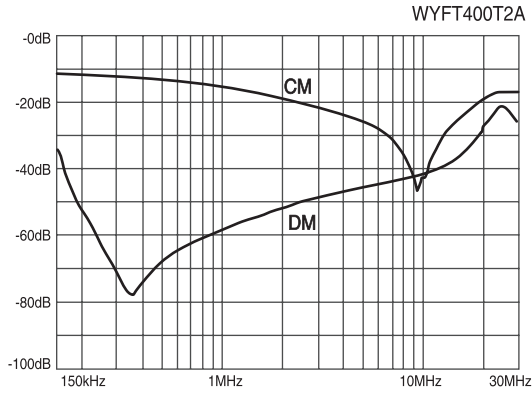

※ CM : Common mode, DM : Differential mode

트랜스포머
REACTOR
리액터
무정전압 레일
SSR
전력조정기
TPR
스위칭파워
SMP
노이즈 필터
H/F
하모닉 필터
SPD
서지보호기
RELAY
보통계전기
E/LD=GF
R
영상변류기
ZCT
METER
판넬메타
CT=VT
계기용 변성기
SHUNT=FA
N

3Ø 250V Characteristics

● Characteristics

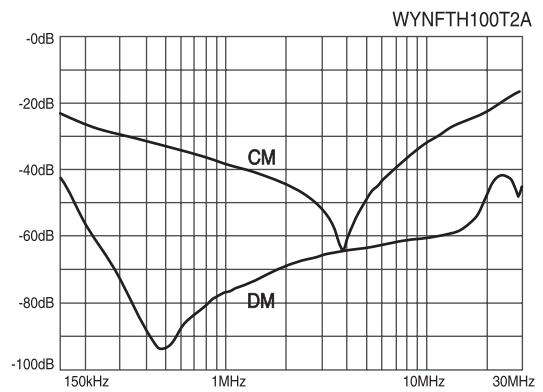
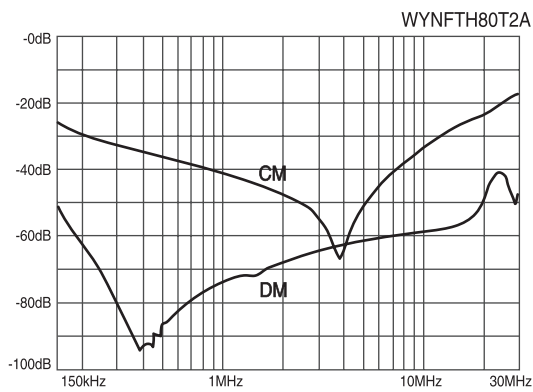
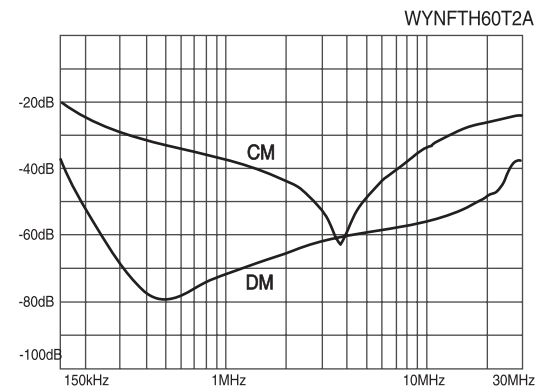
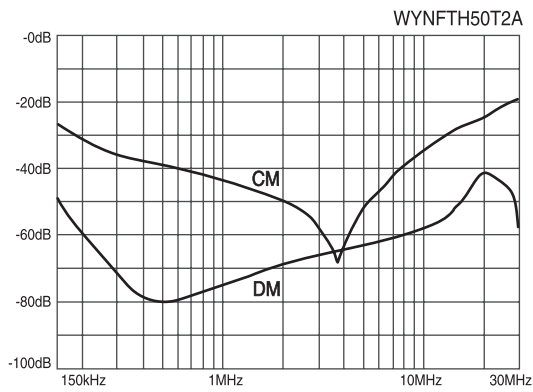
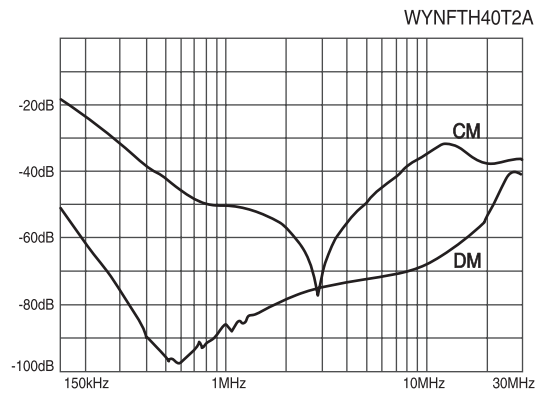
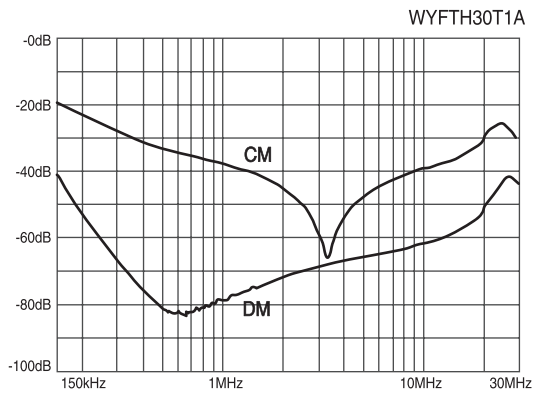
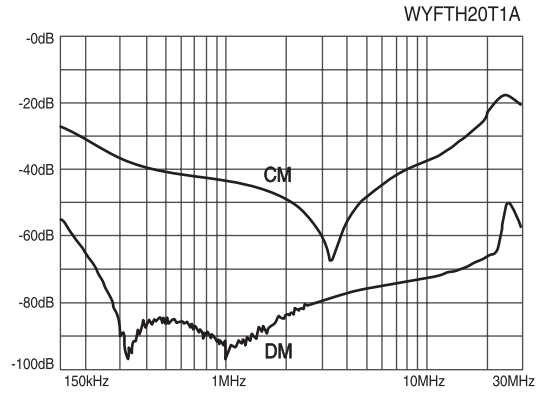
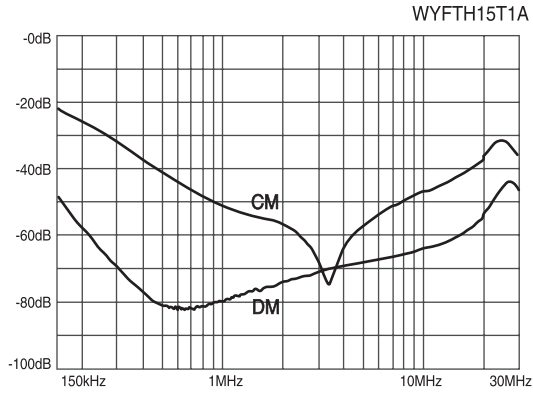

※ CM : Common mode, DM : Differential mode