

# AUTO. BATTERY CHARGER

## Automatic Battery Charger DC12-24V/5A, 10A

- 균등충전 Equalizing Charge
- 부등충전 Floating Charge

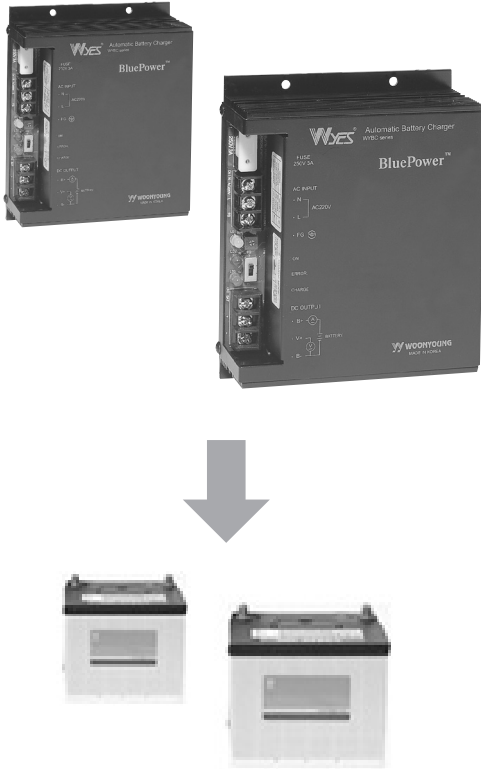

### ● Specification

TYPE		WYBC60S12A(5A) WYBC120S12A(10A)	WYBC120S24A(5A) WYBC240S24A(10A)
OUTPUT		12Vdc	24Vdc
AUX POWER		AC 220V (200~265V) 50/60Hz	
RATING(A)		5A,10A	5A,10A
PHASE		1PHASE	
CHARGING METHOD		Semiconductor Controlling Method	
COOLING METHOD		Natural cooling	
CONTROL METHOD		Automatic, Constant Voltage Constant Current	
EFFICIENCY		More than 70%	
VOLTAGE SETTING	FLOATING CHARGE	13,2Vdc	26,4Vdc
	EQUALIZING CHARGE	14,4Vdc	28,8Vdc
VOLTAGE VARIABLE RANGE	FLOATING CHARGE	13,2V(12~14V)	26,4V(24~28V)
	EQUALIZING CHARGE	14,4V(13~15V)	28,8V(26~30V)
ADJUSTMENT RANGE OF CHARGING CURRENTS		Under 20% out of Rated Currents	
OVER CHARGE TIME		2 Hours at 120% of Rated Voltage	
INSULATION TEST		DC 500V Megger 10MΩ	
WITHSTANDING VOLTAGE TEST		1500V AC, 1/min	
VIBRATION TEST		Thrust Range 0,75mm An Hour for Each Direction of X, Y, Z	
SHOCK TEST		3 Times for Each Direction of X, Y, Z	
OPERATING TEMP.		0 ~ 50°C	
OPERATING HUMIDITY		35~85%RH	
STORAGE TEMP.		-25~65°C (With noising)	
WEIGHT		1 kg	

### ● 각부 명칭 Front Panel Featuring

- ① 제품고정용 Hole
- ② Fuse (AC250V/3A) 20mm
- ③ AC Input AC220V
- ④ 충전기 상태표시램프  
ON - 적색등 : 부등충전시 점등  
녹색등 : 균등충전시에 점등  
ERROR - 적색등 : 축전지를 충전기에 역극성 연결시 점등  
CHARGE - 녹색등 : 축전지를 정확히 연결하고 충전시 점등
- ⑤ 충전전압 가변용 보름 (출하시 최적상태로 설정)
- ⑥ 충전방법 전환 스위치(부등충전/균등충전)
- ⑦ 충전할 축전지 연결단자
- ⑧ 외함 방열판
- ⑨ 라벨
- ⑩ S1 CHARGE MODE 라벨

- ① Mounting Hole
- ② Fuse (AC250V/3A) 20mm
- ③ Power Voltage Input Terminal AC220V
- ④ Display Lamp on the Charger  
ON - Red Light : Floating Charge  
Green Light : Equalizing Charge  
ERROR- Red Light : Reverse connection of a battery into a charger  
CHARGE-Green Light: Correct connection of a battery into a charger; currently being charged
- ⑤ Variable V.R for Charging Voltage (Set at an optimal state when factory)
- ⑥ Charging Method change Switch (Floating/Equalizing Mode)
- ⑦ Connecting Terminal for a Battery for Charging
- ⑧ Outside Heat Sink
- ⑨ Production Model I.D. Label
- ⑩ S1 CHARGE MODE Label

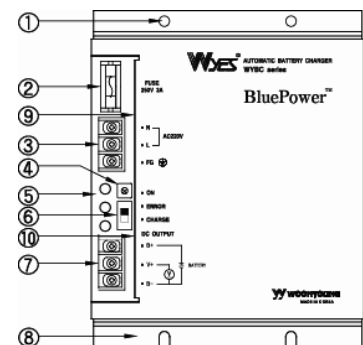

# AUTO. BATTERY CHARGER

## Automatic Battery Charger DC12-24V/5A, DC12-24V/10A

### ● 제품특징

1. 입력전원 표시 램프가 있다.
2. 충전지를 충전기 출력에 잘못 연결시, 충전기를 보호하고 오결선을 표시한다.
3. 입력전원과 충전지가 정확하게 연결되면 충전표시 램프가 점등된다
4. 충전지가 완전 방전되었어도 충전할 수 있는 단자를 갖추었다.
5. 균등, 부동 충전 전압을 현장에서 정확히 설정할 수 있다.
6. 리플전압이 낮아 다른 기기에 영향을 주지 않는다.
7. 충전방식 전환에 원터치 슬라이드 스위치를 적용하여 조작이 극히 간단하고, 결정된 충전방식을 2색LED로 정확히 표시 한다.

### ● 사용방법

1. 입력 전원을 AC INPUT N, L 단자에, 충전지를 DC OUTPUT B+, B- 단자에 각각 연결한다.
2. CONNECTION ERROR(적색) 램프가 점등되면 충전지의 극성이 바뀌었으므로 결선을 점검한다.
3. 입력전원과 충전지가 정확하게 연결되면 충전표시(녹색) 램프가 점등된다.
4. 충전 방식을 선택한다.
5. 초기 충전이나 3개월에 1회정도 약 10시간동안 균등충전을 하여 충전지 각 셀의 충전 불균형을 제거한다.
5. 필요시 VR2 가변저항을 조정하여 정밀하게 맞춘다. (공장에서 조정 출하됨)
6. 전류조정저항 : VR1- 정격전류 차의 ±20% 이하.
7. 충전지 전압이 낮아서 충전이 되지 않으면 V+ 단자에 충전지 "+"를 연결하여 충전하고, 완료되면 다시 B+단자로 옮겨놓는다.

#### - 부동충전 ( FLOATING MODE )

초충전 또는 활성화 충전이 끝난 고정연속충전지를 충전지 및 부하를 병렬로 회로를 구성하고 만충전된 충전지 개회로 전압보다 약간 높은 정전압으로 충전기에 설정하여 놓음으로서 충전지의 자기방전을 보상하여 정전되지 않은 상태라면 항상 만충전된 상태를 유지시켜주는 방식이다.(통상적인 충전위치 )

#### - 부동충전시 유의점

만일 부동충전전압이 너무 낮을 경우는 만충전상태를 유지하지 못하고 극판표면에 썰폐이션을 일으켜 용량 감소가 일어나서 정전시 충분한 방전시간을 지속하지 못한다.

#### - 균등충전 (EQUALIZED MODE)

부동충전으로 장기간 충전지를 운영하게되면 아무리 부동충전 전압을 이상적으로 설정하였다 하더라도 각 단전지간에 전압 및 비중이 균일하지 못하고 차이가 나게 된다. 이때 부동충전 전압보다 약간 높은 정전압으로 충분한 시간동안 충전해 줌으로써 전체에의 전압 및 비중상태를 균등하게 되도록 하기 위한 충전 방식이다.

#### - 균등충전 실시시기

1. 초충전 및 6개월에 1회 정도는 균등충전을 하여야 한다.
2. 년 1회정도는 불필요하더라도 실시한다.

#### - 균등충전시 유의점

만일 균등충전중에 전해액 온도가 45도 이상으로 상승하면 균등충전을 중단하였다가 전해액이 냉각되면 다시 시작해야 한다.

### ● PRODUCT OUT LINE

1. There is a display lamp for input power.
2. If the battery is reverse connected to the charger, the charger will be automatically protected and will be turn on red lamp.
3. If the input voltage and the battery are connected correctly, the green lamp of charging will turn on.
4. Even if the battery is fully discharged, it has a terminal for another round of charging.
5. Equalizing, Floating Charging Voltage can be set precisely on the spot.
6. As the ripple voltage is lower, other equipment is rarely affected.
7. Operation is very simple by the application of one-touch slide switch built for change charging method; and the selected method is clearly indicated on the two-color LED.

### ● HOW to USE

1. Connect the input voltage into the AC INPUT N and L terminal while plug the battery into the DC OUTPUT B+ and B-.
2. If the red light of connection error is on, check the connected lines as it indicates the polarity of the battery is put on backwards.
3. If the input voltage and storage battery are correctly connected, the green light (charging) is on.
4. Select the charging method. Remove any charging imbalances found in the cell of a battery through initial charging or an equalizing charging for about 10 hours once every three months.
5. If necessary, set the currents with precision by adjusting the VR2 variable resistance. (Products are factory setting with the already adjusted currents.)
6. Current Adjustment Resistor : vr1-less than ±20% of the rated current
7. If charging cannot be made due to a low voltage of a battery, try connect of the battery into V+ terminal. When charging is completed, move it back to B+ terminal.

#### - FLOATING MODE

Initial charged battery and load of a fixed footprint lead-acid battery the one that has been charged for the first time or done with active charge as a parallel circuit

While a charger is adjusted at a constant voltage a little bit higher than the one at the open circuit of a fully-charged battery. Thus, it compensates natural discharge of the battery. In other words, if there is no interruption of electric power, the battery is maintained as fully-charged all the time. (with a regular charger)

#### - CAUTION WITH FLOATING CHARGE

If the voltage of floating charge is too low, it cannot be maintained as fully-charged. Furthermore, sulphation will occur on the surface of the plate. This leads to a reduction in weight, failing to sustain enough time for discharge during a power failure.

**T  
R  
A  
N  
S  
F  
O  
R  
M  
E  
R**
**N  
O  
I  
Z  
E  
T  
R  
A  
N  
S  
F  
O  
R  
M  
E  
R**
**S  
S  
R**
**T  
P  
R**
**S  
M  
P  
S**
**N  
I  
F**
**H  
I  
F**
**S  
P  
D**
**R  
E  
L  
A  
Y**
**E  
L  
D**
**G  
F  
R**
**Z  
C  
T**
**M  
E  
T  
E  
R**
**C  
T  
V  
T**
**F  
A  
N**

# AUTO. BATTERY CHARGER

## Automatic Battery Charger DC12-24V/5A, 10A

### - EQUALIZING MODE

When a battery is being run for a longer period of time under the condition of floating charge, voltages and their share between cells inevitably become unbalanced even if the voltage of floating charge has been ideally set. If this is the case, try to charge for enough amount of time with constant voltage set at a little bit higher than the charger voltage. Then the voltages and their share of the overall cells will be evenly charged.

### - WHEN to TRY EQUALIZING MODE

1. For initial charge and once every six months
2. Even if considered unnecessary, try once a year.

### - CAUTION WITH EQUALIZING CHARGE

If the temperature of electrolyte exceeds over 45°... during equalizing charge, stop the charge and re-try it after the electrolyte cools down.

### ● Terminal Connection Diagram

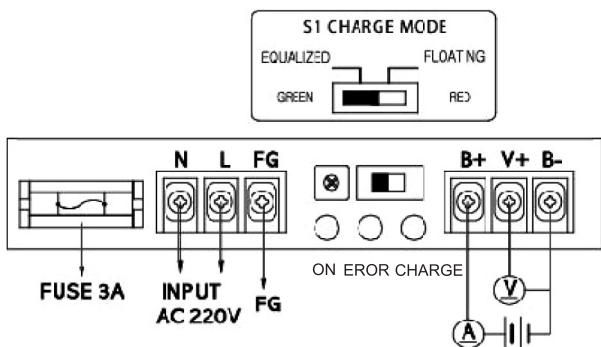

### ● Dimension

