

3PHASE INSTALLING TYPE (3상 일체형) CURRENT TRANSFORMER

0.72~1.2kV (50~1000A)

- Standard :KS C 1706, IEC 61869-2, JEC 1201, IEEE C 57.13



● Features

- 3Phase all in one type
- MCCB mixing type
- Square type C.T(Busbar & Cable installing type)
- Maximum voltage : 1150V
- Over current strength : 40In/1sec.
- Frequency : 50Hz or 60Hz
- Secondary current : 5A
- Case : Poly carbonate (PC)

● Specifications

· 2CT Type

MODEL	MCCB	CT (INPUT)	Primary (A)	Secondary (A)	Class (%)	Burden (VA)	Weight (kg)
WY3CS-162	125AF	2CT TYPE	50~100A	5A	3.0	2.5	0.8
			100~120A		3.0	5	
			100~120A		3.0	15	
WY3CS-262	250AF	2CT TYPE	120~300A		3.0	5	1.1
			200~300A		1.0	5	
			250~300A		1.0	15	
WY3CS-312	400AF	2CT TYPE	250~500A	1.0	15	1.2	
WY3CS-462	630AF	2CT TYPE	500~1000A	1.0	15	2.0	
	800AF						

· 3CT Type

MODEL	MCCB	CT (INPUT)	Primary (A)	Secondary (A)	Class (%)	Burden (VA)	Weight (kg)
WY3CS-163	125AF	3CT TYPE	50~100A	5A	3.0	2.5	0.9
			100~120A		3.0	5	
			100~120A		3.0	15	
WY3CS-263	250AF	3CT TYPE	120~300A		3.0	5	1.2
			200~300A		1.0	5	
			250~300A		1.0	15	
WY3CS-313	400AF	3CT TYPE	250~500A	1.0	15	1.4	
WY3CS-463	630AF	3CT TYPE	500~1000A	1.0	15	2.2	
	800AF						

● Illustration & Drawin

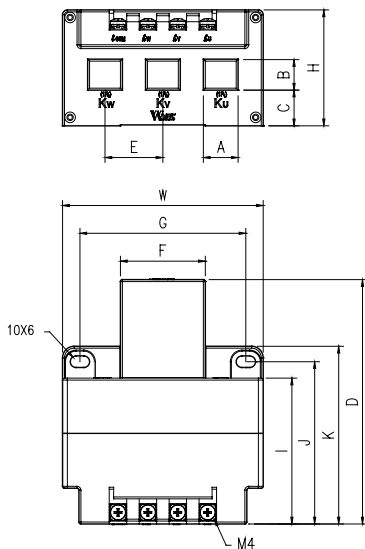

● Connection Diagram

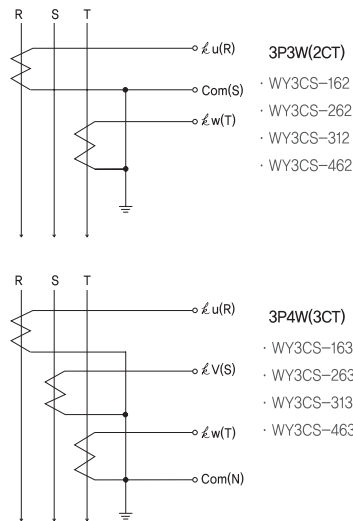

Unit : (mm)

MODEL	W	H	D	A	B	C	E	F	G	I	J	K
WY3CS-162	104	60	126.5	16	14	19.5	30	44	86	75.5	84	92
WY3CS-163												
WY3CS-262	115	60	126.5	26	21	17.5	35	47	97	75.5	84	92
WY3CS-263												
WY3CS-312	145	85	93	31	24	26	44	57	127	58	66.5	74.5
WY3CS-313												
WY3CS-462	215	95	85	46	32	30	70	77	197	51.5	58.5	66.5
WY3CS-463												

고압변류기
HV/CT

고압변압기
HV/VT-MOF

저압변류기
LV/CT

저압변압기
LV/VT

보통계전기
RELA Y

누전경보기
E L D

지락계전기
G F R

영상변류기
Z C T

지시전기계기
M E T E R

선풍기
S H U N T